

Force & Motion 4-5: Pop-ups

Physical Science Comes Alive: Exploring Things that Go
Gary Benenson ✂ City Technology ✂ City College of NY ✂ 212 650 5211

Table of Contents

Introduction.....	2
Lesson 1: Looking Closely at Pop-ups	14
Lesson 2: Make a Pop-up	21
Lesson 3: The Shape of a Pop-up.....	25
Lesson 4: Finding Patterns in the Folds	30
Lesson 5: The Pop-up Computer	43
Lesson 6: Where does it Hide?.....	51
Lesson 7: Stair-step Pop-ups	61
Lesson 8: How they Move	69
Lesson 9: Make an Angle-fold Pop-up	79
Lesson 10: The Monster and the Inside-out Monster	89
Lesson 11: The Peek-a-Boo and the Hand-Waver.....	99
Lesson 12: The Twister	108

Introduction

Overview

This unit introduces paper pop-up mechanisms as an experiential base for elementary science, engineering and math. Pop-ups are three dimensional linkages, which can be made from heavy paper or card stock. Many students have already seen pop-up books and cards, are intrigued by them and would like to make their own. These materials develop spatial visualization, measurement of angles and distances, data analysis, concepts of symmetry and motion, systems thinking and design methods. Pop-ups come in three major categories, depending on their geometry: parallel folds, angle folds, and compound pop-ups, which are combinations of one or both of the two basic types.

Background

The best way to learn about pop-ups is to **examine some** and then **make some pop-ups yourself**. We strongly recommend that you complete at least Lessons 1-3 before reading on. There is simply no way to learn the basics of pop-ups without actually making them! Plus, it can be a lot of fun.

The basic pop-up mechanism is a mechanical device called a **four-bar linkage**. If you are familiar with the [MechAnimations](#) or [ArithMachines](#) unit(s), you may recognize the term **link**, a component of a **linkage**, which in those units consisted of cardboard or pegboard strips. A **bar** is just another word for a link. As the name implies, a four-bar linkage is made from exactly four links. Four-bar linkages are commonly found inside the top of an umbrella; holding the trays of a sewing box or a tool box; on the sides of a shopping cart; in grabbers, used in stores to reach high places; supporting a swing-arm desk lamp; and in construction equipment, such as hoists and cherry pickers. See Figure 1 for some other examples:



Figure 1: Four-bar linkages: fireplace tongs (left); scissor jack (right)

In a pop-up, each link is made from a stiff piece of paper (see Materials, below). The links must be joined by four **pivots** (or joints), to create a single mechanism, whose parts make other parts move. Most four-bar linkages use rivets, pins or screws as pivots. Examples include the devices in Figure 1 as well as the two-dimensional linkages developed in other Physical Science Comes Alive units. In a pop-up mechanism, the pivots are created by folding a piece of paper, or by taping one piece to another, so one piece can swing freely relative to the other. A pivot that works like a fold in paper is called a **hinge**. Hinges and links are the fundamental building blocks of pop-ups.

Guide to the Lessons

This unit is subdivided into 12 lessons, each intended for at least one class period. Each lesson is organized into several sections. * The starred sections do not appear in every lesson.

Overview provides a brief statement of the purpose of the lesson.

Materials lists the supplies needed for the lesson.

Procedure offers a basic lesson plan, including worksheets, focusing questions and prompts for writing entries in the Science Notebooks.

Outcomes provides a statement of the basic conclusions or generalizations to be developed through the lesson.

Assessment offers suggestions for determining how well students have attained the learning outcomes.

* **Extensions** provides additional investigations and design challenges, related to the lesson, that are not essential to the basic sequence. These can be used by students who finish the basic procedure quickly, or for extra sessions, homework or additional assessment.

* **Troubleshooting** offers help to the teacher, pointing out common pitfalls in the construction activities, and how to address them.)

Technical Background provides teachers with background information about relevant science and math.

* **Glossary** provides definitions of key terms used in the Lesson. Like “Troubleshooting” and “Technical Background,” this section is for teachers only, and should not be used as vocabulary for students.

Materials

School Supplies: Most of the materials needed to make pop-ups are typically available in schools. These consist of:

- ✂ Scissors
- ✂ Masking tape or clear tape, ½ or ¾ inch width
- ✂ Rulers
- ✂ Ball-point pens (that need not be working!)

✂ Post-Its™, or paper + glue stick

✂ Markers

✂ Chart paper

Cardstock: Ordinary paper is not stiff enough for making pop-ups. Use cardstock, 65 lb. or higher, bright colors if possible. It is sold in packs of 250 by office supply stores.

Templates: To get students started quickly with pop-up constructions, the unit provides six templates that have cutting, folding and taping lines printed directly on them. All but two of the five templates also display instructions. The first one, the Parallel-Fold Template, does not include instructions, because it is used for a variety of purposes in Lessons 3 through 7. The Angle-Fold Computer Template is used only in the Extension to Lesson 9, which provides instructions for its use. The masters for making the templates are at the end of this Introduction. These masters should be photocopied onto cardstock (see previous item). Table 2 lists the templates and indicates where in the curriculum each one is used.

Storage for student-made pop-ups: In the course of this unit, students will be making and experimenting with many of their own pop-ups. Often their investigations will extend beyond a single lesson, and at the end, the pop-ups made by each student will be part of the record of their work. It is essential, therefore, to provide a way of keeping and distributing their pop-ups. If possible, provide each student with an individual folder for his or her pop-ups; at a minimum, a larger folder, tub or carton should be available for each group.

See-thru book: These are transparent folders made from clear transparency films, used to view the location of a pop-up when the book is closed. Table 2 indicates when the see-thru books are necessary. They are provided along with the templates as part of the curriculum unit. If additional see-thru books are needed, they can be made quickly using transparency films and clear tape. Directions for making a see-thru book are included at the end of this section.

Commercially made pop-up books: We will focus on books in which the motion is powered simply by opening and closing the book. Books that use push- or pull- tabs, or wheels, to generate the motion are sometimes called “pop-ups” in bookstores, but we will not consider them in this unit. We think of pop-up books and their mechanisms as falling into three categories, which we’ll call **simple**, **intermediate** and **complex**:

✂ In a **simple** pop-up book, the construction method is easy to see and understand. The pop-up parts are directly attached to the book, and the motion is towards the center of the book, as in Figure 2 a) or b).

Examples of simple pop-ups are the Giant Pop-Out series published by Chronicle Books; the I Know and Fairy Tales series published by Playmore/ Waldman; Real-Life Pop-up Books, a nature series published by Scientific American for Young Readers/ W. H. Freeman; the Bugs series by David Carter (excluding the many push- and pull-tab mechanisms); pss Pop-up Books published by Price-Stern Sloan; Oh my! a fly by Jan Pienkowski; Snappy Little Bugs; Marvel

Comics' True Believers Retro Character Collection; and most pop-up greeting cards.

✂ **Intermediate** pop-ups are more difficult, but accessible once students have mastered the simple pop-ups. Intermediate constructions are compound mechanisms in which the output of one pop-up is the input to another. These typically produce up-and-down motion in the middle of the page, as in Figure 2 c), rather than towards the spine, as in simple pop-ups.

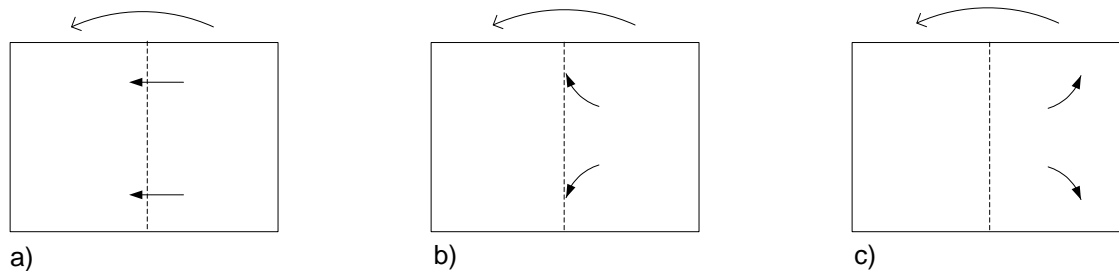

Figure 2: Directions of motion as book opens for typical:
a) Parallel-fold, b) Angle-fold, and c) Compound pop-ups

Intermediate pop-up mechanisms are found in books by Jan Pienkowski (except for Oh my! a fly, see above); Back Pack Books; Horton Hears a Who and Happy Birthday to You by Dr. Seuss; Happy Snappy Books (except for Snappy Little Bugs, see above) by Silver Dolphin Books; and the Busy Bugz published by Templar for Borders Books. Most books by Robert Sabuda are in the “complex” category (see below); however, three of his smaller, earlier books are intermediate: A Kwanzaa Celebration, Cookie Count and Butterflies.

✂ **Complex** pop-ups are useful for getting students’ attention, but are mostly well beyond anything they could make themselves. In this category are Trail by David Pelham; One Red Dot, Blue 2 or 600 Black Spots by David Carter; and any book by Robert Sabuda and/or Matthew Reinhart, with some exceptions noted under Intermediate.

Table 1 shows where in the curriculum each type of pop-up book is used.

Materials	Lessons where used	Total Quantity required
<u>Pop-up books</u> Simple Intermediate Complex	1, 2, 8 7, 8, 9, 10, 11 1, 12	one per two or three students one per two or three students one or two per class
See-thru book	6, 10	three per student
<u>Templates</u> Parallel-fold Angle-Fold Angle-Fold Computer Peek-a-boo Hand-waver Twister	3, 4, 5, 6, 7 8, 9, 10 9 (<u>Extension</u> only) 10 11 12	six per student three per student two per student one per student one per student one per student

Table 1: Materials chart

How to make a See-thru Book from a Transparency Film

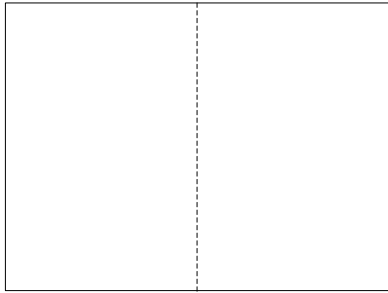

1. Cut in half

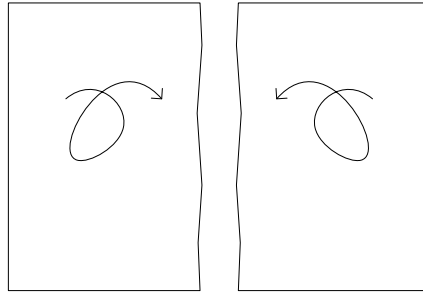

2. Flip so straight edges are facing

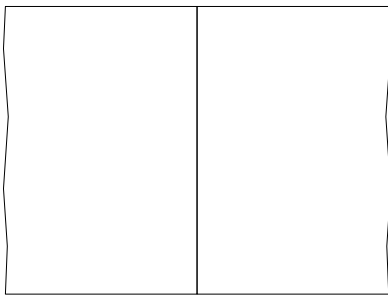

3. Place two sides carefully, so straight edges are just touching

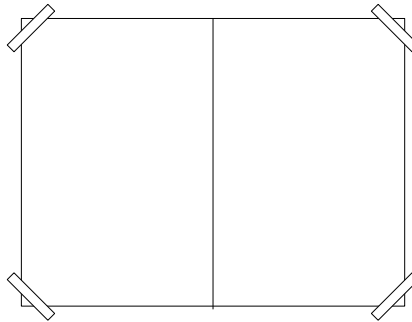

4. Tape outer corners temporarily to prevent shifting

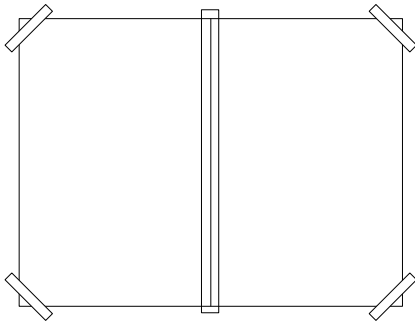

5. Place clear tape carefully along length of seam

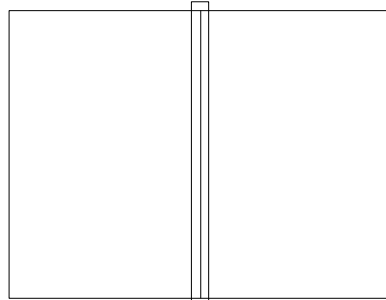

6. Remove temporary tape from corners

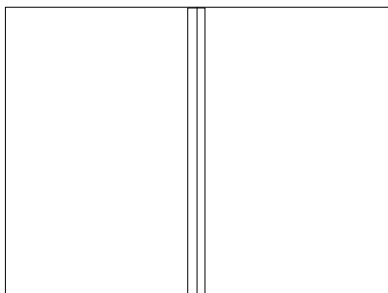

7. Lift carefully and trim excess tape from top and bottom

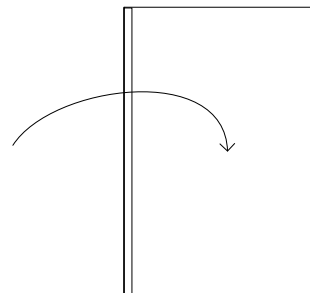

8. Fold and burnish

Parallel-fold Template

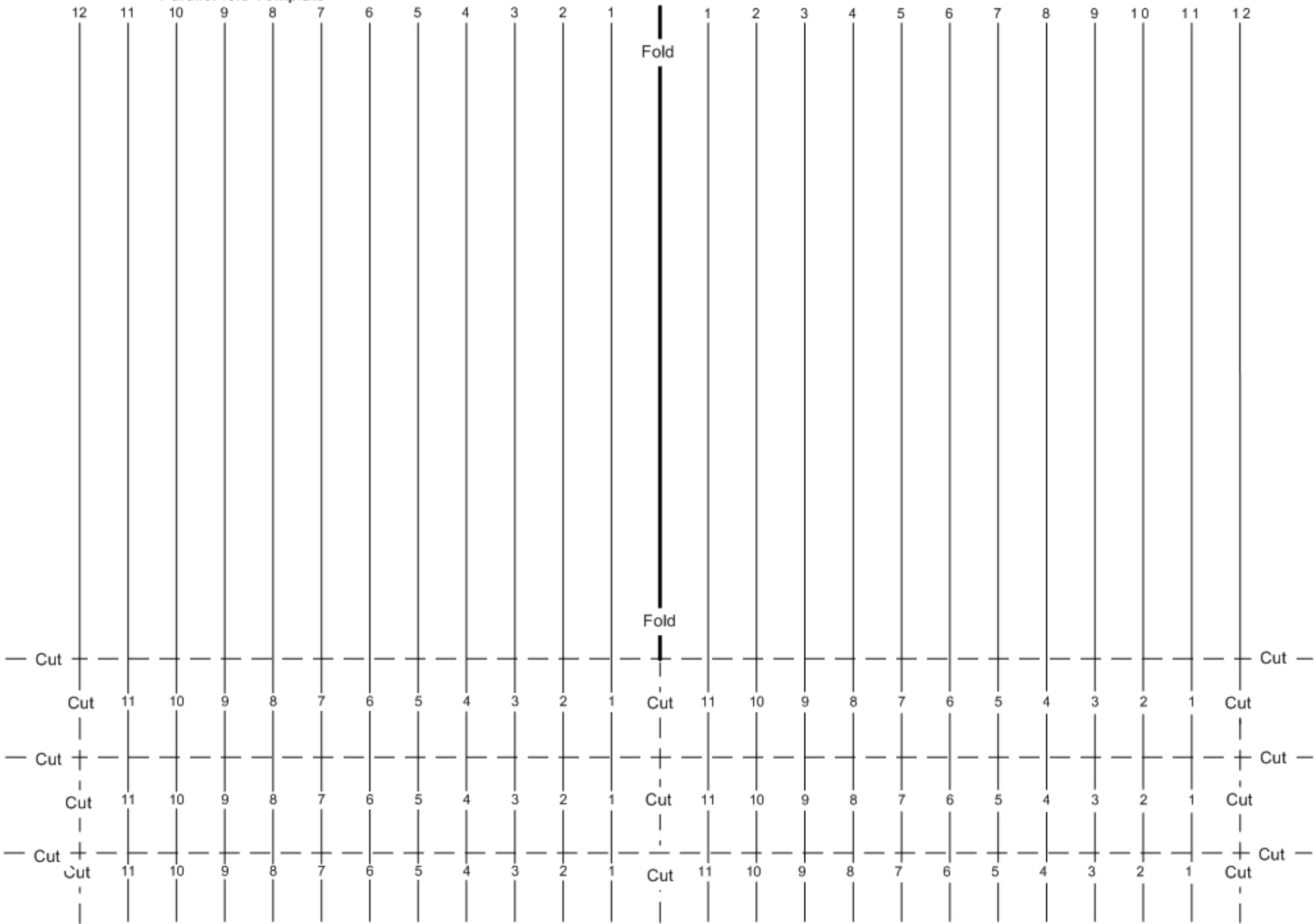

Angle-fold Template

Directions

1. Cut long horizontal line to separate book from the triangles.
2. Fold book on its heavy solid line, using score – fold – burnish technique. .
3. Cut out four triangles along dashed lines. Put three of these aside for later.
4. Fold one triangle along its heavy solid center line using score – fold – burnish technique.
5. Make a flag by cutting a narrow strip from a Post-It, and attach the sticky part in the shaded rectangle, so the rest of the strip extends past the long edge of the triangle. See diagram at right.
6. Tape one triangle to the open folder in the upper position, shown by the dotted lines to the right. Apply tape on the long rectangles.
7. As you begin closing the book, use your finger to pull the triangle up slightly so it folds outwards. Then close the book completely and press hard. Open the book to see it pop up!

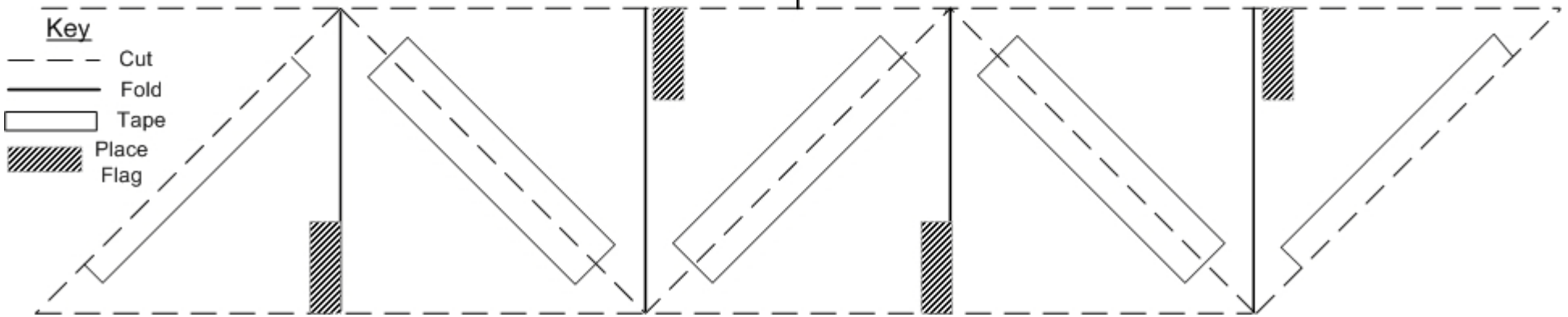
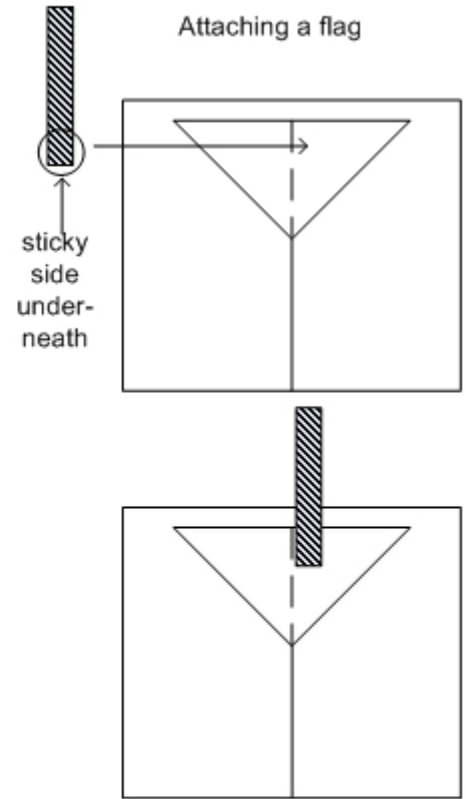
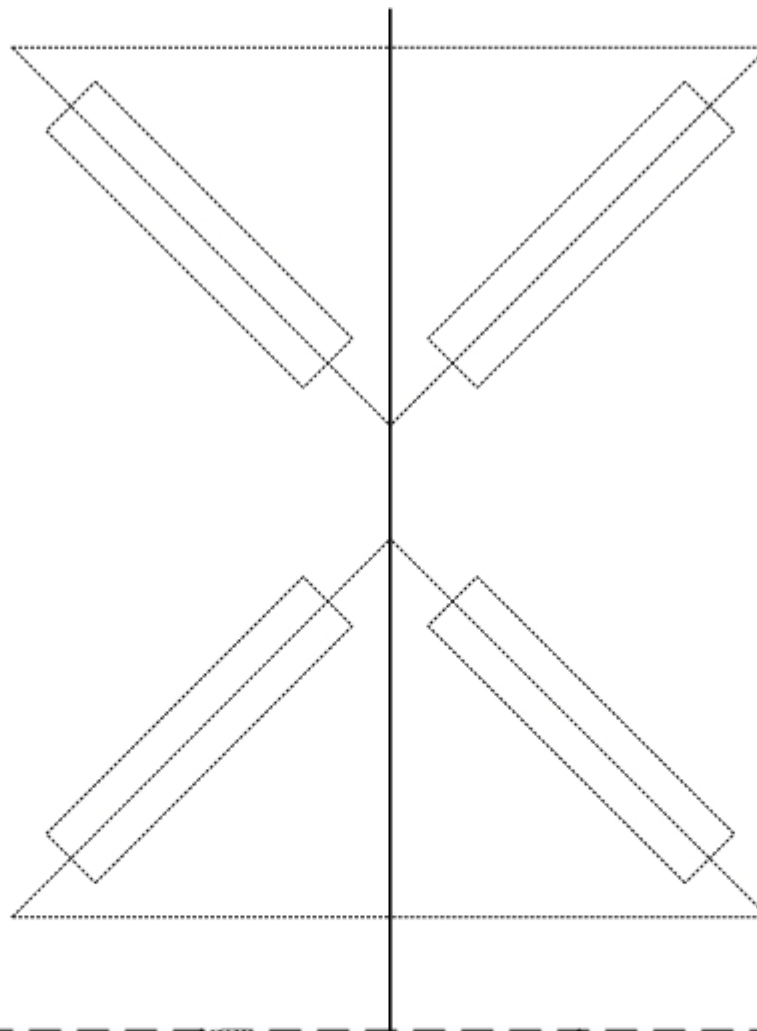

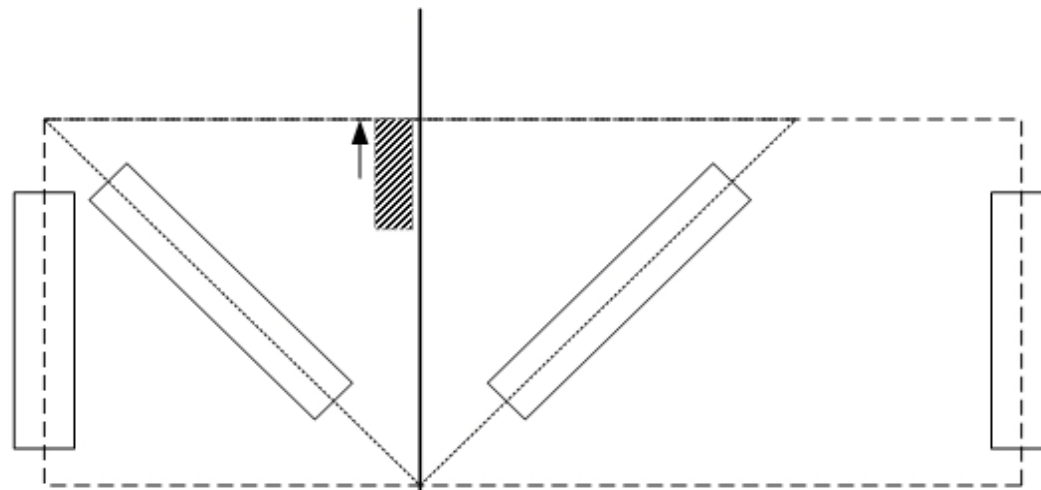

Peek-a-boo Template

Directions

1. Cut along the dashed horizontal line near the bottom of the sheet.
2. Cut out the triangle and rectangle to the right of the Key. The triangle will become the angle fold, and the rectangle will be the parallel fold covering it.
3. Fold the book and the triangle along the heavy solid lines, using the standard technique: score, fold and burnish. Make the fold line in the book point away from you, so the printing is on the inside. Make the fold lines in the triangle and rectangle point towards you, so the printing is on the outside.
4. Tape the triangle to the book as shown. Make sure the vertex touches the gutter, and that neither piece of tape crosses the gutter.
5. Make a flag and attach it to the triangle in the position shown, with the long end sticking out in the direction shown by the arrow.
6. Tape the rectangle flat to the book at the positions shown. As you close the book, pull the parallel fold up gently to make sure it folds outwards. Then close the book completely and press hard to create the parallel fold line.

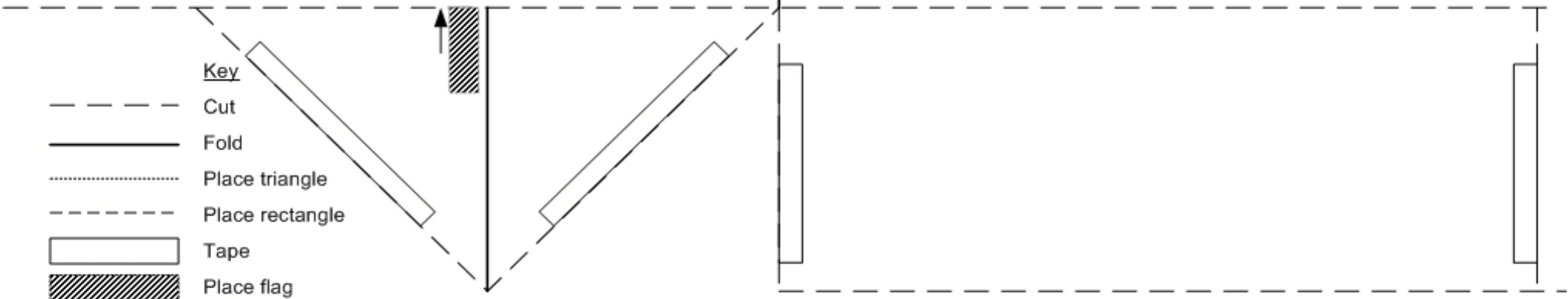

Hand-Waver Template

1. Cut along the dashed horizontal line near the bottom of the sheet. The top portion will become the book.
2. Cut out the rectangle to the right of the Key.
3. Fold the book along the heavy solid lines, using **score-fold-burnish**.
4. Make three folds in the rectangle, again by scoring first. The diagonal folds should point towards you (mountain folds), and the vertical fold should fold away from you (valley fold), forming a little triangular pocket, as shown below. Burnish the whole piece at once.
5. Open the rectangle and tape it to the book in the position shown. Attach a flag to the triangle in the position indicated.

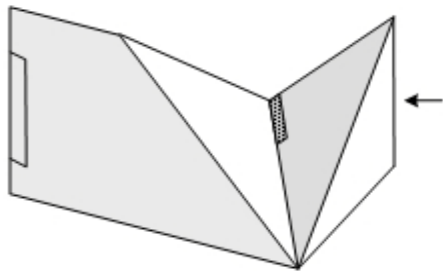
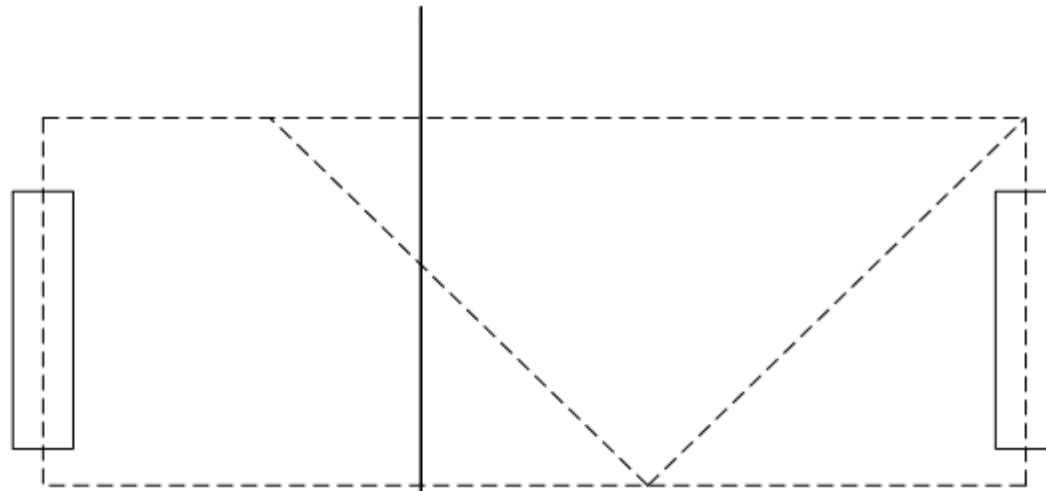

a) Rectangular strip after initial scoring and folding

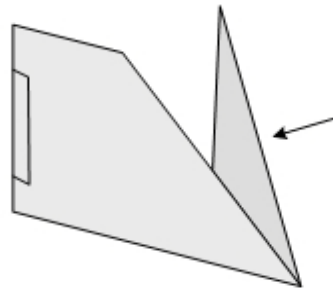

b) pushing it closed

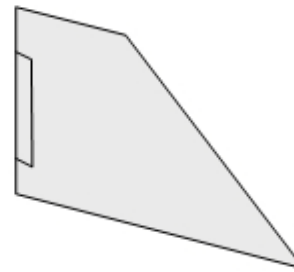

c) folded completely, ready to burnish

Key

- Cut
- Fold inwards (fold pointing away from you)
- ==== Fold outwards (fold pointing toward you)
- - - - Place rectangle
- Tape
- ▨ Place flag

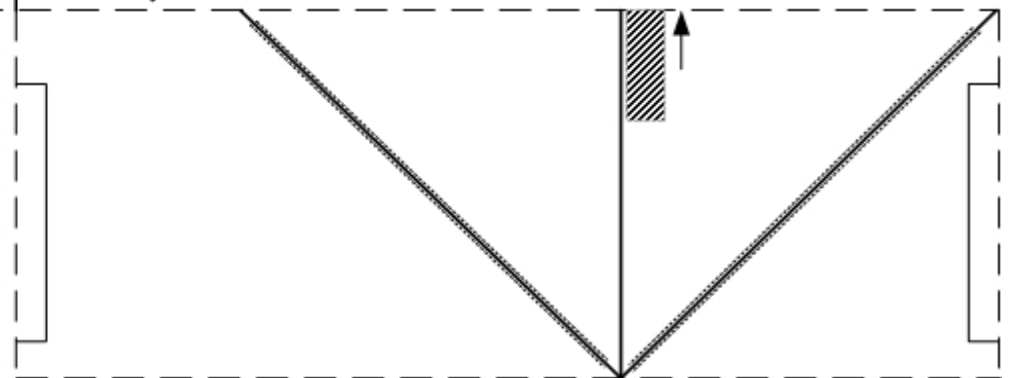

The Twister Template

1. Cut along the dashed horizontal line near the bottom of the sheet. The top portion will become the book.
2. Cut the two triangles and the parallelogram from the horizontal strip.
3. Fold the book and the two triangles along the heavy solid lines, using the **score-fold-burnish** technique. Make sure the fold line of the book is away from you and the fold lines on the triangles point towards you.
4. Tape the triangles to the book to make the two angle folds, applying tape as shown by the long rectangles. Test them to make sure they work smoothly.
5. Apply tape **under** the horizontal sides of two opposite triangles, sticky side up, where indicated by rectangles. This tape will attach the parallelogram. See Figure a).
6. Place the parallelogram bridge across the two opposite edges of the angle folds, so the horizontal ends line up. Then curl the tape over the top and press hard. See Figure b)
7. Close the book, pulling the bridge up gently to make sure it folds outwards, and press the book shut to force the fold in the bridge.

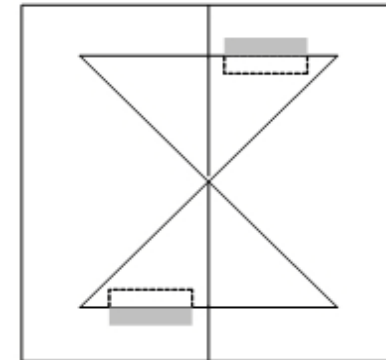
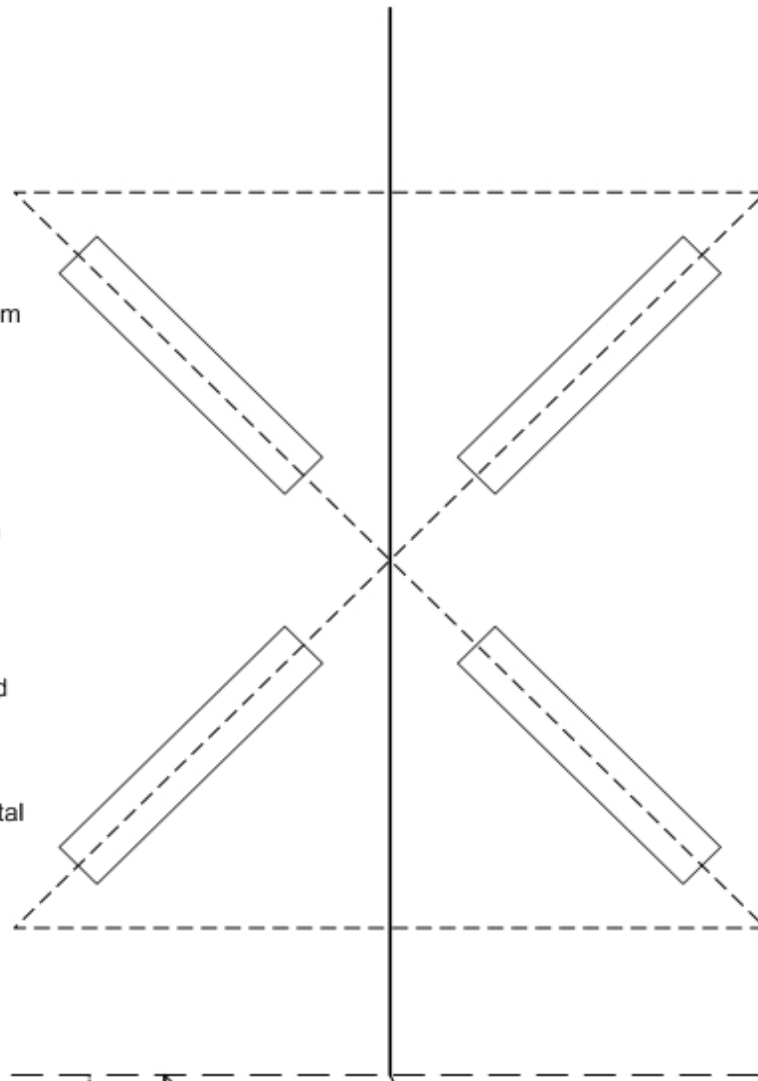

a) tape on underside of two triangles, sticky side up

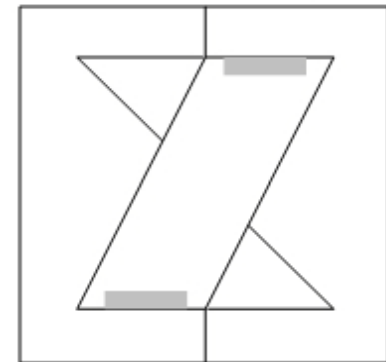

b) tape parallelogram in place, tape folded over

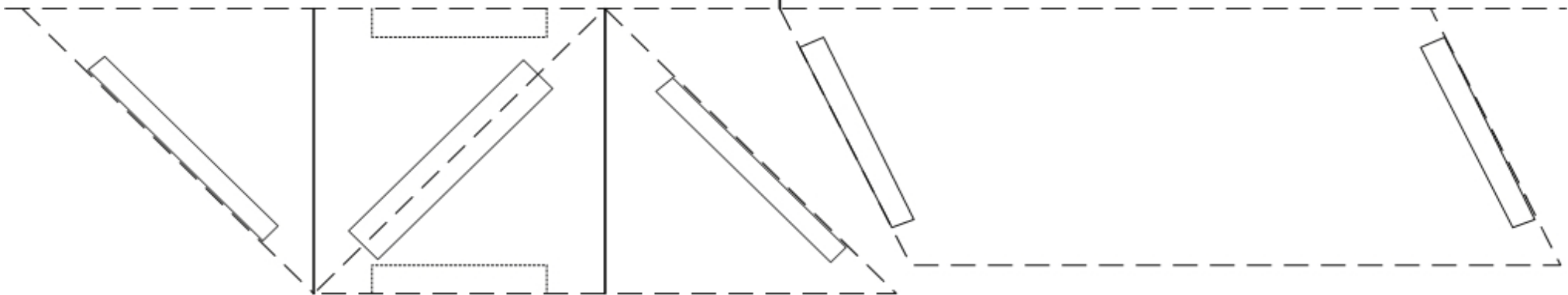

Angle-Fold
Computer
Template

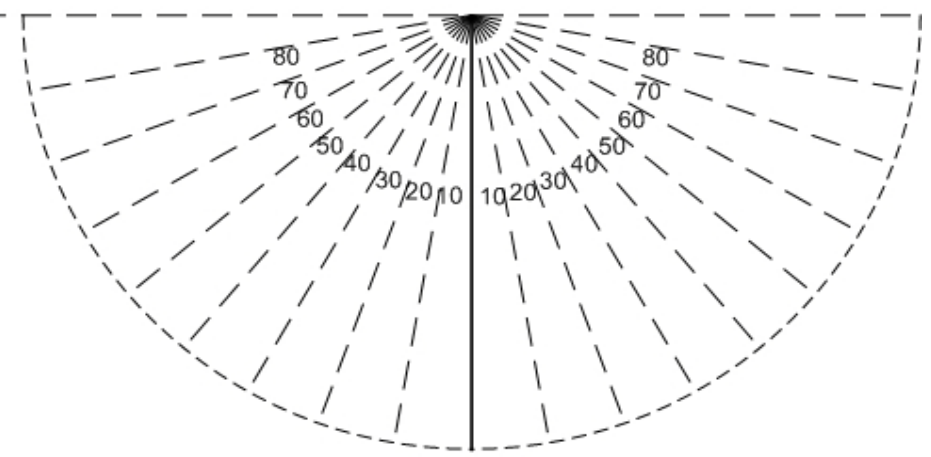
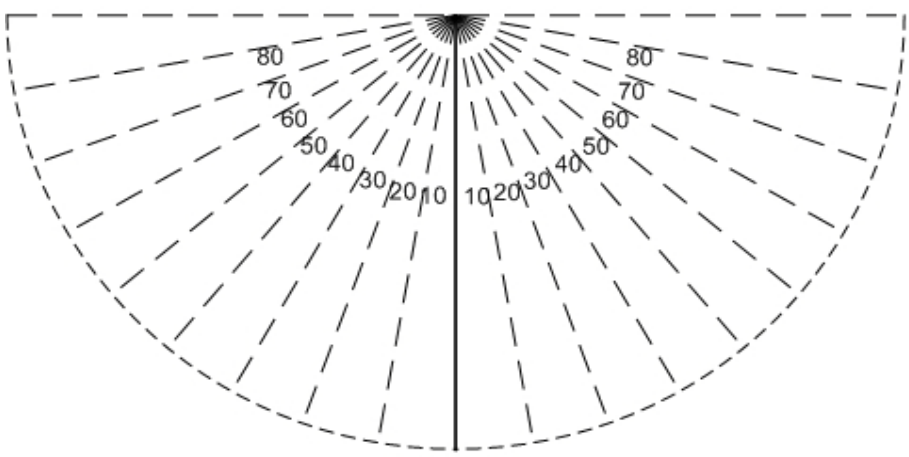
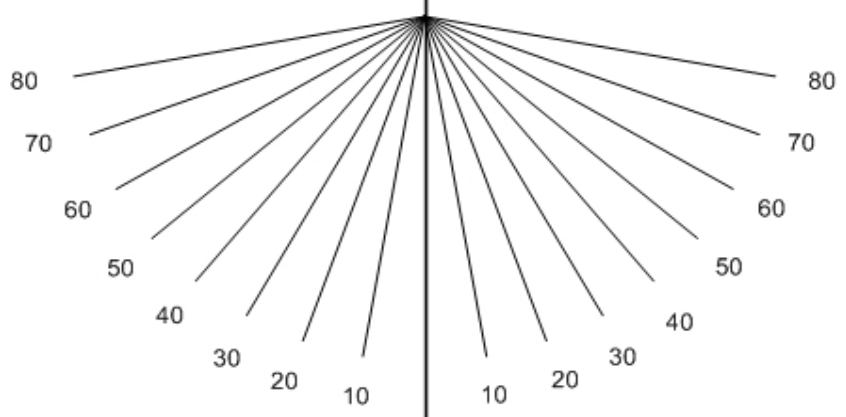
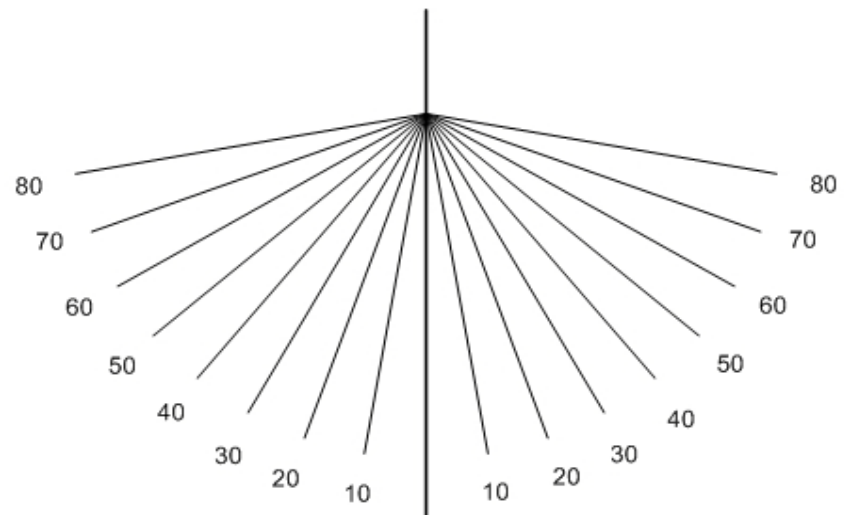

Lesson 1: Looking Closely at Pop-ups

Overview

Students begin their study of pop-ups by examining pop-ups that have been made commercially. After making general observations, they focus on the parts of a pop-up, what causes the pop-up action, and how the pieces need to be arranged for this action to occur.

Materials

- ✂ One **complex** pop-up book.
- ✂ An assortment of **simple** pop-up books and/or cards, about 3 or 4 per group (see [Introduction](#), pp. 6-7).
- ✂ Science Notebooks

Procedure

1. **Examining Pop-ups:** Demonstrate to the class the one **complex** pop-up book, opening each page several times slowly so that students can see the complex motions powered by the book. Explain that this sort of book is difficult to make, and definitely not for beginners! However, there are lots of pop-up ideas that are easy to figure out and make yourself. Provide several **simple** pop-up books for each group to share. Tell the students that they will be looking at these pop-ups to learn what they need to know so they can make their own. Ask one person from each group to record the group's observations about the pop-ups.
2. **Group reports on pop-ups:** Convene the entire class, and ask each group to report one item at a time, going around the room as many times as necessary, until all the items have been reported. Each item should not duplicate those that have already been reported. Record all the items on the blackboard or chart paper for everyone to see.
3. **Focus on Function and Structure:** Many of the items reported in #2 are likely to be general observations or impressions, such as “they’re colorful,” “surprising” or “tell a story.” The purpose of this next activity is to analyze how the pop-ups work and how they are constructed. This is the information we’ll need to make our own pop-ups.

Identify the items on the chart that are related to the operation of a pop-up, such as:

- ✂ It has moving parts;
- ✂ To make it pop up, you have to open the book;
- ✂ There’s an inside part and an outside part;
- ✂ It has folds;
- ✂ It has to be attached on both sides.

Encourage students to draw on these observations when they answer the next three questions in their Science Notebooks.

Science Notebooks

1. What **parts** does the simplest pop-up need to have in order to work?
2. What do you **have to do** to the pop-up book to make something pop-up?
3. How do **the parts need to be attached or arranged to cause the pop-up action?**

Then conduct a whole class discussion about these three questions, asking each group to report one item at a time, as before. Record the ideas from the whole-class meeting on chart paper.

4. Keeping track of the Parts. To facilitate discussion, it is helpful when everybody can use the same names to mean the same things. Introduce the standard names used by “paper engineers,” the people who design and make pop-ups professionally (see Figure 1 and [Glossary](#)). Post these names on chart paper so everyone can see them. Finally, ask students to record their observations about the three questions using the standard names you have introduced.

As students are doing the worksheet, you might point out how much shorter the answers can be once you’ve agreed on standard words for things.

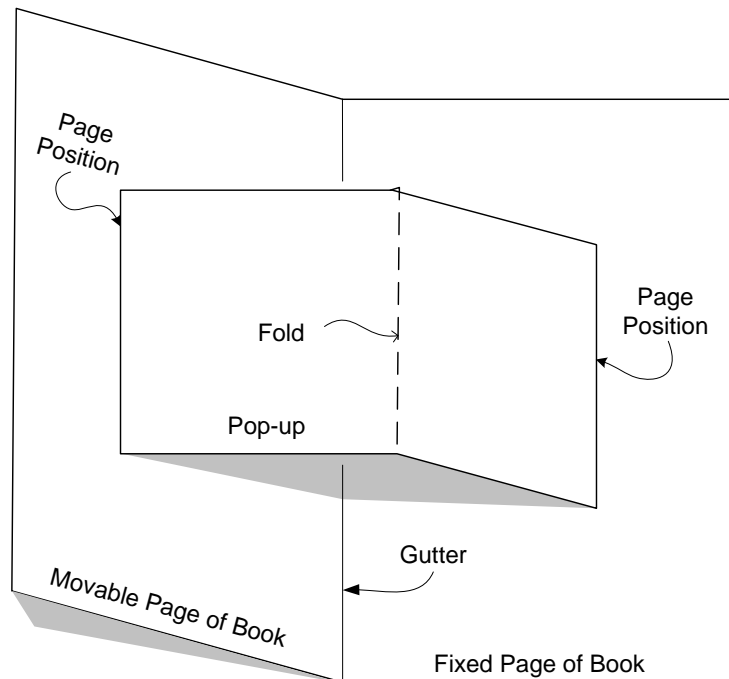
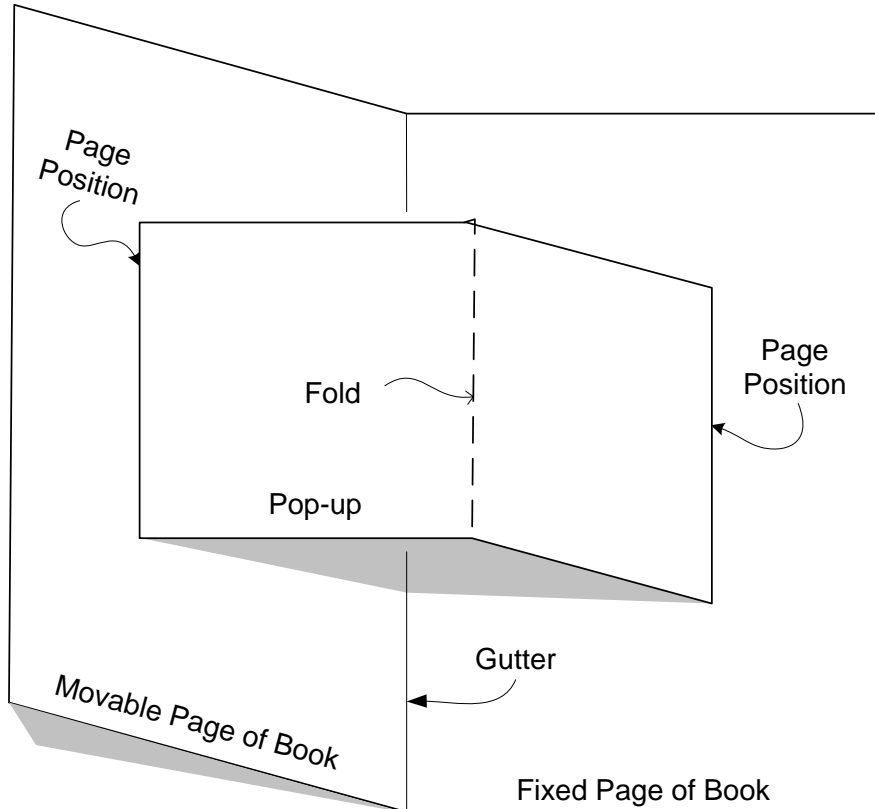

Figure 1: Standard names for the pop-up parts

Ask students to attach their worksheets to their science notebooks. Save classroom charts for future lessons

Name: _____ Date: _____

Lesson 1: The Features of a Pop-up



1. What parts does a pop-up need to have ?	
2. What do you have to do to the pop-up book to make something pop-up ?	
3. How do the parts need to be attached to cause the pop-up action ?	

Outcomes

By the end of the lesson, students should develop an understanding that:

1. A pop-up mechanism requires two pieces of paper: one for the **book** and another for the **pop-up** piece.
2. The pop-up is powered by **opening and closing the book**.
3. The pop-up has to be attached to the book at **two page positions**. There has to be a **page position on each side of the gutter**. The pop-up has to have a **fold**, which should point **outwards** (towards you).

Assessment

1. Demonstrate a mechanism that isn't a pop-up. It could be a slide mechanism, operated by a push or pull tab or a wheel; or a spring, which "pop-ups up" when the book is opened by releasing the energy stored in the spring, which is attached to one page of the book only. Ask:
 - ✂ What is making this move?
 - ✂ What has to be the answer to this question for something to count as a "pop-up"?
 - ✂ Should this one be considered a "pop-up"? Why or why not?
2. Demonstrate a pop-up cut from one piece, like in Figure 2. (These are common in very simple pop-up books.)

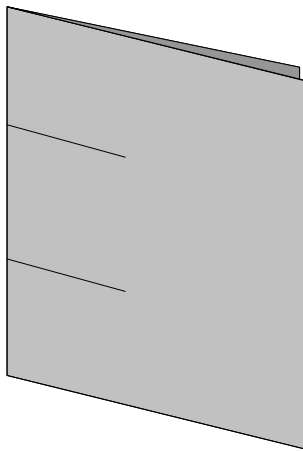

a) Book closed, two slits cut across gutter

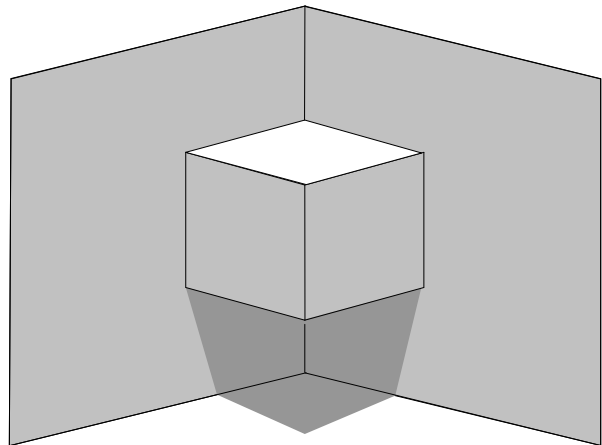

b) Book open, center pushed outward between slits

Figure 2: Pop-up cut from one piece, leaving a hole in the back

- ✂ Is this a pop-up? Why or why not?
- ✂ How many pieces are needed to make it?
- ✂ If you made it from only one piece, what would happen in the back?

Technical Background

What parts does a pop-up need to have in order to work?

Students should notice that a pop-up needs to be made from at least two pieces of paper. In the simplest pop-up, one piece is inside the book, and the other piece forms the book itself. Additional observations might include:

- ✂ There is a fold in each piece.
- ✂ You need tape or glue to attach the pieces.
- ✂ You need a scissors to cut the pieces.
- ✂ Sometimes, the inside part and the outside part are made from the same piece of paper, but this leaves a hole in the back. The hole must be filled by a second piece of paper, so there still need to be two pieces. See Figure 2.

What do you have to do to the pop-up book to make something pop-up?

This question may be a little confusing. Students may think you're asking how to make a pop-up book. Explain that you're talking about a pop-up book that someone has already made. What do you need to do to it to make something pop up?

With this clarification, most students will recognize that ...

- ✂ ... the motion of the pop-up is caused by opening and closing the book.

This should be true of all the mechanisms you've selected as examples (see [Introduction](#), p. 8). It does not apply to mechanisms powered by input tabs or "up-pops," which are actually springs attached to only one page of the base, released when the other page is opened. The input to a true pop-up is the motion of the book only.

How do the parts need to be attached or arranged to cause the pop-up action?

This is the hardest of the three questions. If necessary, help students focus on whether and how the two pieces need to be connected in order for the pop-up to work. Call their attention to:

- ✂ Where things are folded;
- ✂ The directions of the folds (inwards or outwards);
- ✂ How the pieces are attached: in how many places, where and why.

Some observations might be:

- ✂ The book has to fold inwards (away from you) as you close it.
- ✂ The pop-up has to fold outwards (towards you) as the book closes.
- ✂ In order to work, the pop-up needs to be attached to the book (page positions) on both sides of its center fold (gutter).

Engage the class in thinking about why all of these are true. The observations about the two folds are fairly obvious. The book has to fold away from you, or you wouldn't see the pop-up – it would be on the other side! The pop-up has to fold

towards you – in the opposite direction from the book’s fold – or it wouldn’t come out towards, which is the basic idea of a pop-up. In Origami, the fold in the book would be called a **valley fold**, while the fold in the pop-up would be called a **mountain fold**.

The reason for needing two attachments is that the book has to transmit a force to one side of the pop-up piece, which must be resisted by the book on the other side. Suppose we keep the right side of the book fixed, and move the left side only. Try making a pop-up by attaching the pop-up piece to the left side only. Then disconnect it and attach it to the right side only.

What goes wrong in each case? If the pop-up is attached only to the left side, the pop-up piece won’t be anchored, so it will simply follow the left side as in Figure 3 a). On the other hand, suppose it’s attached only on the right side, as in Figure 3 b). When the book opens, the pop-up won’t follow it, because the force of the moving page won’t be transmitted to it. To achieve pop-up action, the pop-up piece has to be attached to both sides, because it needs to be both anchored to the fixed side, and pushed or pulled by the movable side, as shown in Figure 3 c). The attachment of the pop-up to the book can be made using tape, glue, or tabs-in-slots.

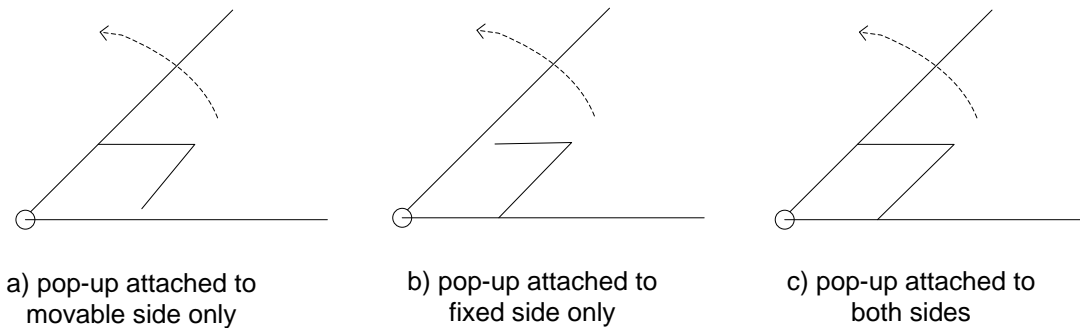

Figure 3: Why a pop-up has to be attached to both sides of the gutter

Illustrated Glossary

Attachment: Connection between pieces makes them move together.

Book: The folder or outside cover of a pop-up mechanism. A book consists of two **links**, separated by a **hinge** called the **gutter**.

Fold: The **hinge** in the pop-up piece that separates it into two links

Force: Push or pull needed to start something moving.

Hinge: A line where either or both of two links can rotate, like a door or cabinet hinge. In a basic pop-up there are four hinges: the **gutter**, **fold** and two **page positions**. See Figure 4 a).

Link: A flat, rigid piece of a mechanism, attached to other links by **hinges**. In a basic pop-up there are four links: two **pages**, which make up the **book**, and two sides of the pop-up piece, separated by the **fold**. See Figure 4 b).

Linkage: A type of mechanism consisting of links and hinges.

Mechanism: A device with moving parts.

Page positions: The two places, one on each side of the gutter, where the pop-up is attached to the book. These have to allow the sides of the pop-up piece to rotate, and are therefore **hinges**.

Pages: The two sides of the book, separated by the gutter.

Pop-up piece: The inside piece of a pop-up mechanism. The pop-up consists of two **links**, separated by a **hinge** called the **fold**.

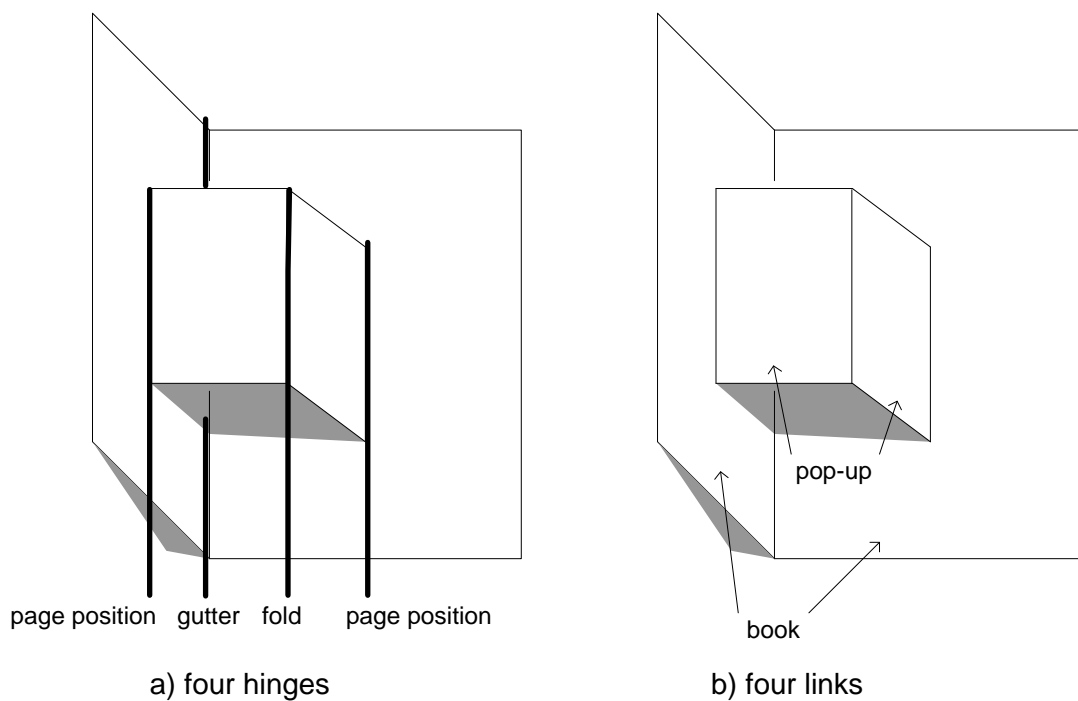

Figure 4: The links and hinges of a pop-up

Lesson 2: Make a Pop-up

Overview

Based on what they have learned in Lesson 1, students try to make their own pop-ups. As they do, they keep track of issues that arose, and of steps they took to address these issues.

Materials

- ✂ Books or cards with **simple** pop-ups, two or three per group. Some of the pop-ups should be parallel folds.
- ✂ **Cardstock** in a variety of colors, two or three sheets per student.
- ✂ **Scissors**, one or two per group
- ✂ **Masking or cellophane tape**, 1/2" or 3/4" wide, one roll per group
- ✂ **Folders** or other containers for saving pop-ups, at least one per group
- ✂ **Charts from Lesson 1**
- ✂ **Science notebooks**
- ✂ **Markers or crayons, glue, Post-Its™** for decoration and creating messages.

Procedure

1. **Discussion of Troubleshooting:** Explain that in a few minutes, the students will be making their own pop-ups. Many of these will not work immediately. Ask:

✂ **If something doesn't work right away, what should you do?**

Help students develop the idea that they can figure out what's wrong with something that doesn't work. Most things that are faulty have only one thing wrong with them. It doesn't make sense to start over again, because, most of it actually does work! Also, if they start over, they might make the same mistake again. A much better procedure is to **troubleshoot**: find the part that doesn't work, and then fix only that part. Ask students to provide examples of troubleshooting from their experience.

Then explain that many of the issues that come up might be easy to solve. In fact, the answers might already be in their science notebooks, based on what they observed about the pop-ups they examined in Lesson 1.

2. **Making pop-ups:** Provide materials and simple pop-ups to each group. Each student's task is to make a working pop-up. For reference, they should use their conclusions recorded in the Lesson 1 Worksheet, which might also be posted on chart paper. For example, if a student tapes the pop-up on only one side of the book, or places tape across the gutter, point out their conclusion that the pop-up needs to be attached on both sides of the gutter. Finally, ask the students to keep track of **issues** that come up as they work, and methods they used for troubleshooting them. These will be helpful to the whole class in learning more about how to make pop-ups.

Science Notebook: As they work, or immediately afterwards, they should record the following information in their Notebooks:

1. **What you did:** Use pictures and words to describe how you tried to make a pop-up.
2. **Issues:** Things that didn't work out the way you wanted.
3. **Troubleshooting:** How you tried to solve each problem, and how well it worked.

As students are working, highlight their successes, by showing successful designs to the entire class. Meanwhile, collect a list of issues that they bring to your attention. Some of these will appear in the **Problems** section of their Notebooks. Others they might not write down, because they didn't know how to solve them, or didn't see them as issues. Look out for students who don't ask for help, but nevertheless have serious difficulties in making a pop-up. You may need to work with them individually, or pair them with other students who can help them.

After most students have created pop-ups, ask the class to wrap up. If students work quickly, and don't get too involved in making decorations or cutouts, this could occur well before the end of the period. Ask the students to report their lists of **Issues**. Then add any that came to your attention, but that they may have forgotten to write down or report.

Students should save all their work in their folders. If you want them to continue working on their pop-ups for homework, provide new materials, so the existing work stays in the classroom.

Outcomes

By the end of this lesson, every student should have made his or her own pop-up, and should be able to explain how to make one. They should also have identified any issues that came up, and steps they took to resolve the simpler issues.

Assessment

The actual pop-ups and the Science Notebooks should provide evidence that they are able to make a pop-up and describe how to make one.

Technical Background

It is helpful to organize the Issues into two separate lists: (a) those that are relatively easy to solve, and (b) those that are not. On the first list, leave room for another column on the right, to show what they did (or would do) to solve the problem. Table 1 has some examples.

Problem	Solution
Tape won't stick.	<ul style="list-style-type: none"> ✂ Use wider or longer tape. ✂ Place tape so it sticks to both pop-up and book. ✂ Press tape harder.
Pop-up piece is too small to stick.	Use a bigger piece.
Paper bends too much.	Use cardstock instead of regular paper.
Things get in the way of each other.	Start simple – use fewer pieces.
Won't pop up.	<ul style="list-style-type: none"> ✂ Attach pop-up on both sides of the gutter. ✂ Don't tape across gutter. ✂ Make sure fold is pointing outwards.

Table 1: Pop-up issues that are not hard to fix

The information on this list may help some students troubleshoot their own problems. Troubleshooting is a key activity in design, technology and engineering. It includes both identifying the source of the problem, and then taking steps to address it. Often, students will simply want to destroy anything that doesn't work, and start over again. This approach is counterproductive for at least two reasons:

- ✂ Usually, most of what they made actually did work; there's no point in making it again. It's more efficient to find the part that doesn't work, and change only that part.
- ✂ Unless they've understood the problem, there's a very good chance that they'll simply reproduce the problem when you make another one.

Troubleshooting involves higher-order thinking, because it requires that you perform an analysis to determine the source of the problem, and then take steps to solve only that problem.

While many of the issues in making pop-ups will give way to troubleshooting, there are also some that will require more knowledge to figure out. These will be the basis of the next set of activities, which involve more systematic investigations of the parallel-fold, or which require the other type of pop-up, the angle-fold. Table 2 lists examples of this second category of issues, along with the lessons that provide clues about how to solve each one.

Issue	Lesson(s) that address this issue
Book won't close without making a new fold	3, 4 & 5
Pop-up sticks out when book is closed	5 & 6
Pop-up should lie flat (instead of standing up) when book is open	4, 5 & 6
Pop-up should stand up (instead of lying flat) when book is open	4, 5 & 6
Pop-up should move up-and-down instead of back-and-forth	8, 9 & 10
It should be more surprising	10, 11 & 12
Stuff should spring out beyond the book when it opens	10
Would like to have more than one pop-up in the same folder	7, 9, 10, 11 & 12
Would like to make a pop-up that makes another one move	7, 11 &, 12

Table 2: Issues that will be addressed later in the unit

Glossary

Troubleshooting: Identifying the cause of a problem, and then fixing what's causing it

Lesson 3: The Shape of a Pop-up

Overview

Students begin addressing some of the issues that arose in Lesson 2 by investigating the shape of a pop-up before and after the book is closed for the first time. They discover that a pop-up mechanism forces a fold to be made at a specific location in the pop-up piece.

Materials

- ✂ **Scissors and tape**
- ✂ **Ball-point pens and rulers**, for making sharp folds. The pens don't have to write.
- ✂ **Parallel-fold Template**, printed or photocopied onto 8 ½" x 11" cardstock (see [Introduction](#)).
- ✂ **Folders** or other containers for saving pop-ups

Procedure

1. Using the template: Provide each student with the [Parallel-fold Template](#) and ask them to cut out the six 12 cm. strips, along the dashed lines. Note that the lines at 1 through 11 cm. are labeled, but not the two ends, at 0 and 12 cm., which are dashed. To make the book from the larger piece, fold it along the heavy center line to make the center line or gutter. See box below for tips on how to make a sharp fold. Make sure the vertical lines are inside the book – these will soon be used for measuring!

How to make a fold

1. **Score** the fold line by pressing hard along it, with a ballpoint pen, using a ruler as a guide to make sure the line is straight.
2. **Fold** the paper gently; it will naturally find the score line you have made.
3. Close the book, and **burnish** the fold by pressing along its length with a hard object, such as a scissors handle, fingernail or ruler.

2. How does it close? Have each student tape one of the strips (unfolded) into the card. They should recall from Lesson 1 that there has to be a page position (attachment line) on each side of the gutter. These lines should lie along the ruler lines printed in the book.

The model before closing should look like Figure 1.

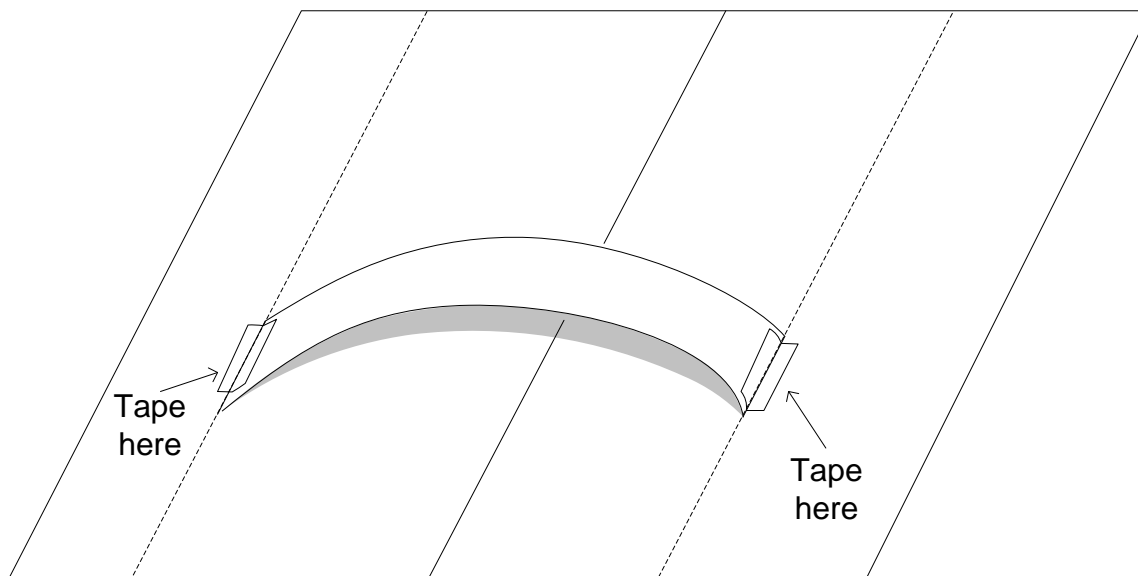

Figure 1: Book before closing

Show students how to look at something from an “edge view:”

1. Hold a single piece of ordinary paper with both hands so all you can see is the bottom edge. Close one eye. Instead of a rectangle, the sheet should look like a line.
2. Now do the same thing with the open book. The book itself look like a straight line, and the pop-up piece should be a curved line above it. See Figure 2 a).

Then challenge them to imagine – but not yet test – what their books will look like from an edge view after they close it and then open it again. **They should not try the experiment until after they have made their predictions.**

Science Notebook:

1. **Draw** what the book looks like **before** you close it.
2. Make a **drawing** showing your **prediction** of what the pop-up will look like **after** you close the book, and then open it again.

Once they have made their predictions, allow students to close and then open their books and see if their predictions were valid. Many students will be surprised to find that the book makes a fold in the strip. Ask them to draw and describe the shape before and after folding. One student said: “First it was an arch, but the book turned it into a triangle!” See Figure 2 b).

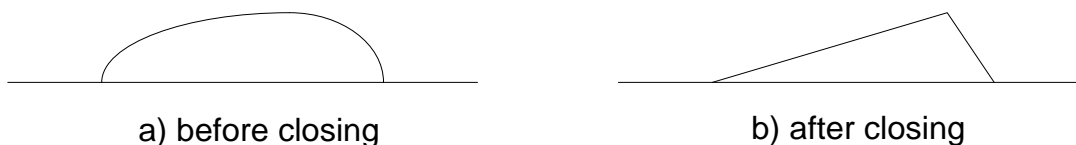

Figure 2: Pop-up before and after closing

Science Notebook:

1. **Describe** how you did the experiment.
2. Use both pictures and words to show what the pop-up **looked like** after you closed the book, and then opened it again.
2. **Explain** why the pop-up looked the way it did.

Engage the class in a discussion of the predictions they made, what the results were, and why they came out the way they did.

3. **Does it always make the fold in the same place?** Ask students to tape two more strips into the book. One should be taped at the **same page positions** as the first strip, and the third should be taped at **different page positions**. Remind students that the page position is the distance from the gutter where the pop-up piece (strip) is taped into the book. The book has centimeter rulers printed in it, starting at the gutter, so it should be easy to see where the page positions are.

Science Notebook:

1. **Predict** whether all three strips will wind up with folds in the same places.
2. **Describe** what happened when you did the experiment.
3. **Explain** why you think the folds are where they are.

4. **How many folds?** Here is a related experiment. Fold another strip cross-wise at some point before taping it in. See Figure 3. First, they should predict what will happen to the pop-up piece, then close the book and finally open it again to see what happened.

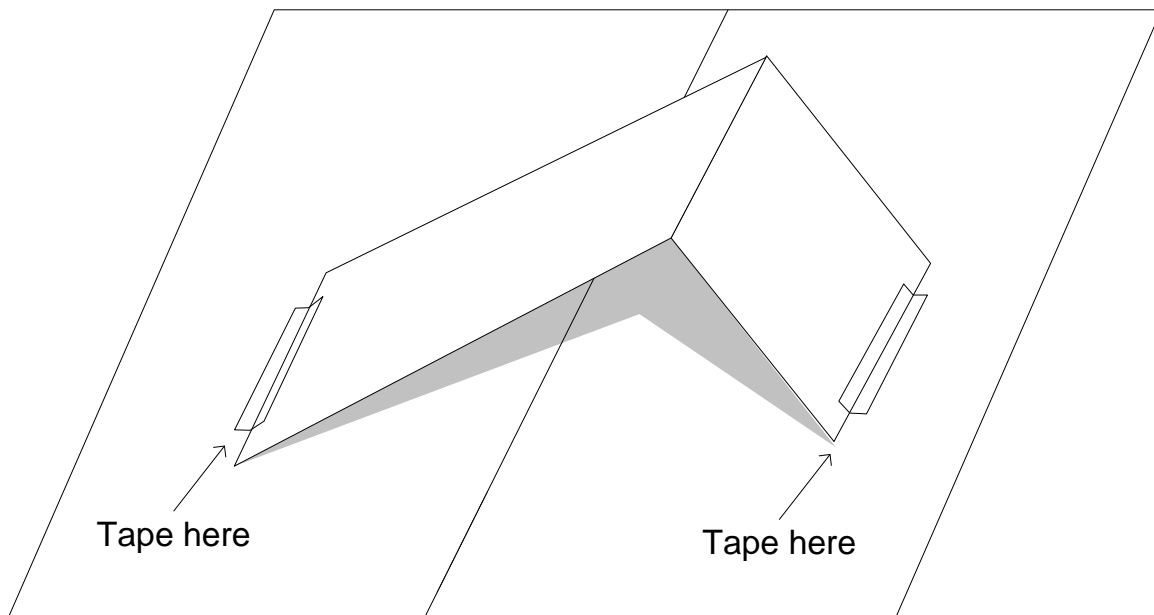

Figure 3: Pop-up folded before closing the book.

Science Notebook: 1. **Predict** what the folded strip will look like after you open the book.

2. **Describe** whether or not your prediction was correct.

3. **Explain** why the pop-up did or did not come out with another fold.

Lead a discussion about these experiments.

- ✂ What was surprising about what happened each time?
- ✂ If you don't make a fold in the strip first, what does the book do?
- ✂ If you do make a fold in the strip first, what does the book do?
- ✂ If you tape two strips at the same page positions, where do the folds wind up?
- ✂ If you tape two strips at different page positions, where do the folds wind up?
- ✂ What patterns do they notice in these results?
- ✂ What is the book "trying to do each time?"

Outcomes

In the course of this lesson, students should find out that:

- ✂ A pop-up book always makes a fold in the pop-up, even if it didn't have one to start with. By forcing the fold to happen, the book changes the shape of the strip from an upside down "U" to an upside-down "V."
- ✂ The location of the fold on the pop-up piece depends on the page positions. Students might notice that the fold is always on the side that has the largest page position – i.e., is taped in furthest from the gutter (see Lesson 4).
- ✂ If the pop-up piece has a fold in it before it is taped in, closing and opening the book will make a fold anyway, usually in a different place from the original fold. The book makes a fold in the pop-up piece based on the locations of the page positions, not on where the original folds were. One student explained: "The first fold you control, the second fold is controlled by the book."

Assessment

- ✂ Show students a pop-up folder with an unfolded strip taped in. Ask them what will happen if you try to close the book without forcing it to shut.
- ✂ Show students a pop-up folder with an unfolded strip taped in. Ask them what they think will happen if you try to close the book without forcing it to shut. Will it "like" your original fold? If not, what will it do? What will happen if you force it to close?
- ✂ Make a pop-up by taping a strip into the book unfolded, close and open the book, and demonstrate where the fold is. Remove the strip by carefully untaping it, and move it to two new page positions. Ask students what they think will happen when you close the book and then open it again.

Troubleshooting

Sometimes the pop-up piece won't stay attached to the book. The problem is usually in the way the tape was applied. Figure 4 shows some Do's and Don't's.

The tape should run along the edge of the strip, with as much surface area as possible attaching it to both the book and the strip, as in Figure 4 a). If the tape is applied cross-wise, as in Figure 4 b), it may not stick enough to hold the pieces together. If the tape is too long, as in Figure 4 c), it will prevent to pop-up from rotating, resulting either in additional folds, or the tape coming loose. Also, the edge of the strip should be taped parallel to the ruler lines, or the pop-up may be forced to twist or come loose. Figure 4 d) shows a pop-up that does not meet this guideline.

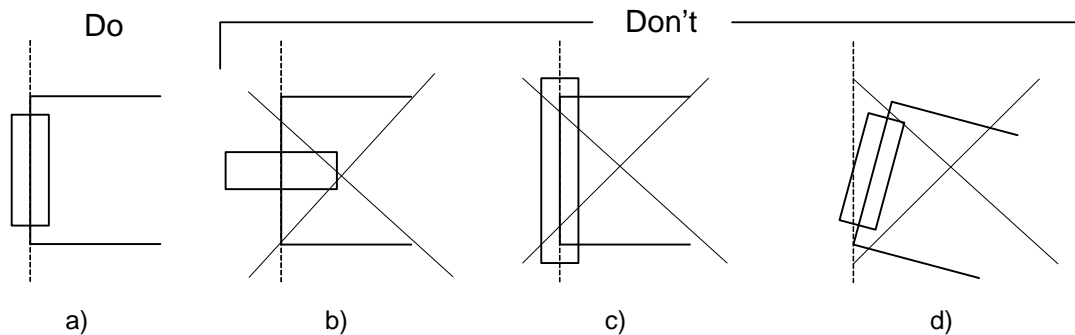

Figure 4: How to apply the tape: a) good technique; b) tape applied cross-wise; c) too much tape; d) pop-up piece is oblique to ruler lines

Technical Background

Closing the book always causes a fold to form in the pop-up piece. Even if the pop-up is folded beforehand, the book usually ignores this fold and makes a new one. How does it decide where to make the fold? Actually, it solves a math problem, which is developed in Lesson 5, and explained in Lesson 6. The next lesson prepares the way to see this problem, through two qualitative investigations.

Lesson 4: Finding Patterns in the Folds

Overview

Students tape multiple strips into the book, varying the page positions systematically. They investigate two questions:

- If a strip is taped closer on one side of the gutter than on the other, where will the fold be?
- If strips are taped at equal distances on either side, but both page positions are closer to the gutter on one construction than on another, what will be different about the resulting pop-ups?

Materials

- ✂ **Scissors and tape**
- ✂ **Ball-point pens and rulers**, for making sharp folds. The pens don't have to write.
- ✂ Two **Parallel-fold Templates** per student, printed or photocopied onto 8 1/2" x 11" cardstock.
- ✂ **Science notebooks**
- ✂ **Folders** for saving students' pop-ups

Procedure

1. Near and far: In the previous lesson, we learned that closing the book always makes a fold in the pop-up. We also learned that the location of this fold depends on the page positions. To find out more about where the fold will be, we'll do two experiments where we change the page positions systematically, and see what pattern this makes in the folds.

Provide each student with the Parallel-fold Template and Worksheet 1. As in Lesson 3, students begin by cutting the six 12 cm. strips, and making the fold in the book. They then tape five strips at different page positions in the book, according to Table 1. The strips should not be folded first. Use a marker to label each pop-up with a number, to keep track of them.

Pop-up	Page positions	
	Left side	Right side
#1	1 cm.	9 cm.
#2	3 cm	7 cm.
#3	5 cm.	5 cm.
#4	7 cm.	3 cm.
#5	9 cm.	1 cm.

Table 1: Distances from page position to gutter for the experiment "Near and far"

After they have assembled the five strips into the book, but before they close the book, ask students to think about how this experiment has been set up:

- ✂ Why is it better not to fold the strips first? What would happen if they were already folded?
- ✂ What is the same about the way each strip is taped in? What is different about them?
- ✂ What pattern do they predict will happen in the folds?

Chart their predictions.

Then ask students to conduct the experiment: simply close the book, open it again, and look for patterns in the folds. Worksheet 1 provides a format for writing their observations and conclusions. Discuss the results with the class. Here are some focusing questions:

- ✂ Look at Pop-up #1. Look at where the two sides are taped in. Now look at the others. What do you notice? How are the other pop-ups taped in differently from this one?
- ✂ Now go back to Pop-up #1. Look at where it makes the fold. Now look at the others. What do you notice? How are the other fold lines different from this one?
- ✂ Generalize. What pattern connects where a pop-up was taped in with where it makes the fold?
- ✂ If the pop-up is taped in symmetrically (same distance on both sides), where will the fold line be?

2. High and low: In doing the previous experiment, students may have noticed that when the strip is centered, the fold line will come out in the center too. Introduce the concept of **symmetry**. Ask a volunteer to stand in front of the room. What about them is symmetric? What is not? Draw or show models of various organisms and objects that have some symmetries, such as a ball, box, dog, tree, car or airplane. If the models are small and an overhead projector is available, use it to project their images from different viewpoints. Most letters have some form of symmetry, such as A, B, C, D & E. Others are asymmetric, such as F & G.

- ✂ Which (if any) of the pop-ups in the first experiment was **symmetric**?
- ✂ To make a symmetric pop-up, what do you have to do?

Once students have recognized that a symmetric pop-up would have the same page positions on each side (like Pop-up #3 in the previous experiment), explain that in this next experiment, all the pop-ups will be symmetric. Provide each student with a Parallel-fold Template and Worksheet 2. As in the previous experiment, students begin by cutting the six 12 cm. strips, and making the fold in the book. They then tape four strips at different page positions in the book, according to Table 2. The strips should not be folded first. Use a marker to label each pop-up with a number, to keep track of them.

Pop-up #	Page positions (Distances from gutter)	
	Left side	Right side
#1	3 cm.	3 cm.
#2	4 cm.	4 cm.
#3	5 cm.	5 cm.
#4	6 cm.	6 cm.

Table 2: Distances from page position to gutter for the experiment “High and low”

After they have assembled the four strips into the book, but before they close the book, ask students to think about how this experiment has been set up:

- ✂ What is the same about the way each strip is taped in? What is different among them?
- ✂ What pattern do they predict they will see when they close the book and then open it again?

Chart their predictions.

Then ask students to conduct the experiment: simply close the book, open it again, and look for patterns in the pop-ups. Worksheet 2 provides a format for writing their observations and conclusions. Discuss the results with the class. Here are some focusing questions:

- ✂ Look at Pop-up #1. Look at where the two sides are taped in. Now look at the others. What do you notice? How are the other pop-ups taped in differently from this one?
- ✂ Now go back to Pop-up #1. Look at where it makes the fold. Now look at the others. What do you notice? How are the other pop-ups different from this one?
- ✂ Generalize. What pattern connects where a pop-up was taped in with how it looks after it makes the fold?

At the end of the lesson, students should attach the worksheets to their Science Notebooks.

Name: _____ Date: _____

Worksheet 1: **Near and Far**

1. **Set-up.** Tape five 12 cm. strips into the book at the page positions shown. **Do not fold the strips.** Use a marker to label each strip with its number.

Pop-up #	Page positions (Distances from gutter)	
	Left side	Right side
#1	1 cm.	9 cm.
#2	3 cm	7 cm.
#3	5 cm.	5 cm.
#4	7 cm.	3 cm.
#5	9 cm.	1 cm.

2. **How the experiment is set up:** (before you close the book)

What is the same about each strip? _____

What is different among the strips? _____

What do you think the strips will look like after you close the book?

Name: _____ Date: _____

Near & Far, continued

3. **Results of the experiment:** Close the book, open it again, and look at it from an edge view. Draw Pop-up #1 and pop-up #5, as you see them from an edge view:

Pop-up #1

Pop-up # 5

What is different between them? _____

What patterns do you notice about where the folds are made?

Name: _____ Date: _____

Worksheet 2: High and Low

1. **Set-up.** Tape four 12 cm. strips into the book at the page positions shown. **Do not fold the strips.** Label each strip with its number.

Pop-up #	Page positions (Distances from gutter)	
	Left side	Right side
#1	3 cm.	3 cm.
#2	4 cm.	4 cm.
#3	5 cm.	5 cm.
#4	6 cm.	6 cm.

2. **How the experiment is set up:** (before you close the book)

What is the same about each strip? _____

What is different among the strips? _____

What do you think the strips will look like after you close the book?

Name: _____ Date: _____

High & Low, continued

3. Results of the experiment: Close the book, open it again, and look at what happened from an edge view. Draw two of the pop-ups, one which is taped closer to the gutter, and one which is further:

Taped closer to gutter

Taped further from gutter

What differences do you notice between the two pop-ups you drew?

Outcomes

The two experiments should produce the following conclusions:

Near and Far:

- ✂ The pop-up always makes the fold on the far side, unless it is symmetric.
- ✂ If it is symmetric, it will make the fold in the center.

High and Low:

- ✂ The closer the page positions are to the gutter, the higher the fold line and pop-up.

Assessment

Design questions:

- ✂ If I want to make a pop-up that has its fold on the left side, how should I tape it in the book?
- ✂ If my pop-up doesn't stand up as high as I want it to when the book is open, what should I do to make it stand higher?

Inquiry questions:

An **input** (or **independent**) **variable** is a quantity that I change deliberately to see what will change as a result. An **output** (or **dependent**) **variable** is the quantity that I look for, to see how it changed as a result of my changing the input variable. A **controlled variable** is one that I keep the same each time, so that I am only changing one thing at a time.

- ✂ Identify the input variable, output variable and controlled variable in the first experiment, **Near and Far**.
- ✂ In this experiment, how does changing the input variable affect the output variable?
- ✂ Identify the input variable, output variable and controlled variable in the second experiment, **High and Low**.
- ✂ In this experiment, how does changing the input variable affect the output variable?

Troubleshooting

Most of the problems in doing these experiments arise from poor taping techniques. Please refer to the Troubleshooting section of Lesson 3.

Technical Background

1. **Near and Far:** In the first experiment, there are two **controlled variables**:

- ✂ the distance between page positions is always 10 cm.
- ✂ the strip length is always 12 cm.

One page position is the **input variable** (the other page position is always 10 cm. away). The location of the resulting fold line is the **output variable**.

Each pop-up has a **near side** (closer to the gutter) and a **far side** (further from the gutter), except for #3, which is symmetric. The experiment shows that closing the book always forces **the fold line to be on the far side**, unless the pop-up is symmetric, in which case the fold line will be centered.

Figure 1 shows the outcome of the experiment for a book with five strips, with the near side and far identified for pop-up #5 only. For #1 & #2, the far side is on the right, and in both, the fold is on the right too. The opposite is true for #4 and #5. In #3, both the strip and the fold are centered. To measure how far each side is actually taped from the gutter, students can use the vertical lines inside the card, which show the distance from the gutter in cm.

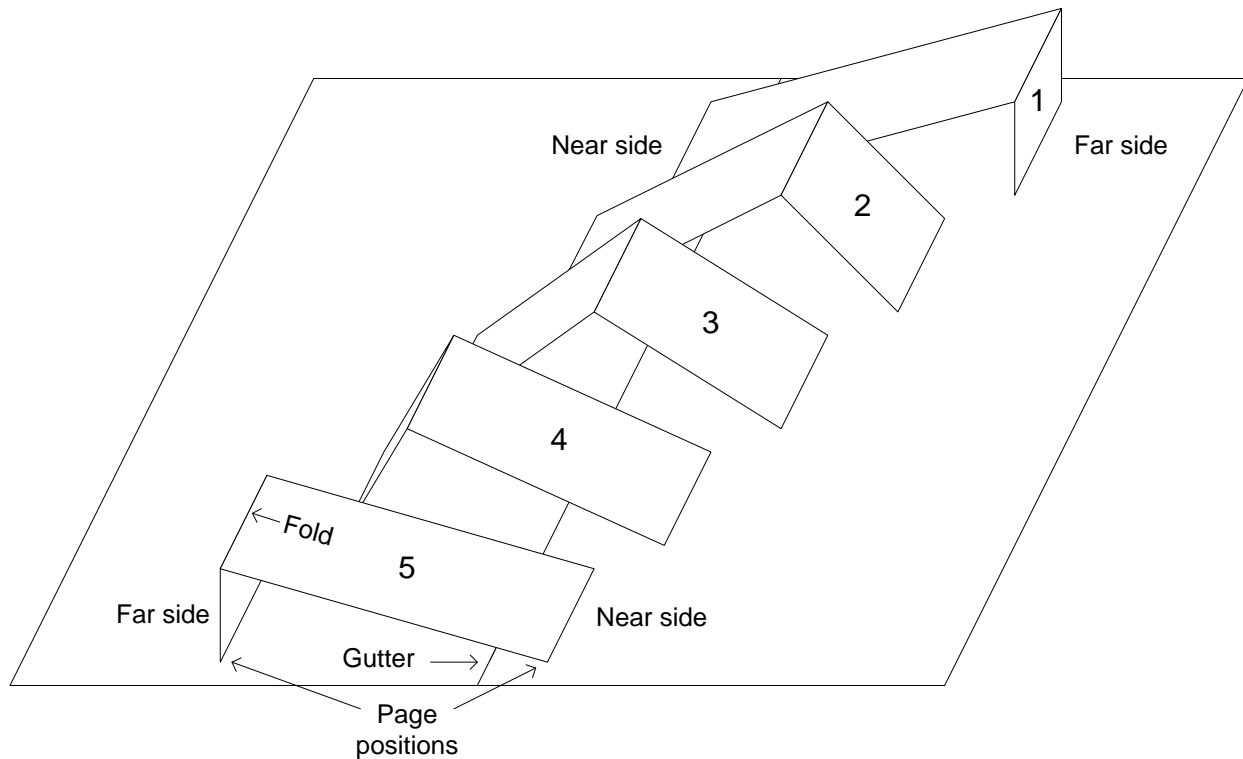

Figure 1: It always makes the fold on the far side

To understand the pattern, recall from Lesson 1 how we identified the four links of a pop-up, separated by the four hinge lines. Two of the links are on the two sides of the book, starting at the gutter and extending to the page positions. The other two links are the two sides of the pop-up, separated by the fold. To keep track of these more easily, let's identify them as A, B, C and D, as shown in Figure 2.

Figure 3 is similar to Figure 1, showing pop-ups #1, #3 and #5 only, with links A, B, C and D labeled. From Figure 3, it should be clear what the book is “trying” to do when it makes the fold:

- ✂ Pop-up #3 is symmetric, so A and D are already equal. There is no reason B & C shouldn't be equal too, so the book makes the fold in the center of the pop-up.
- ✂ In #1, we've made A much longer than D. To compensate, the book folds the pop-up on the right (far) side, so it makes C much longer than B. This way, the two links on the right side, A & B, are adjusted to adjust them to be like the links on the left side, C & D.
- ✂ #5 is exactly the opposite of #1. There, D is longer than A, so the book makes C short and B long to equalize the lengths on the two sides.

This information is summarized in Table 3.

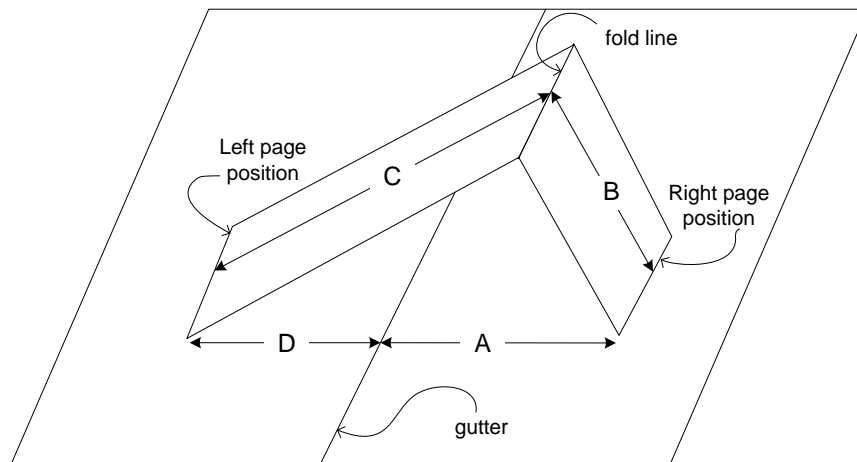

Figure 2: The four links again, now identified as A, B, C & D

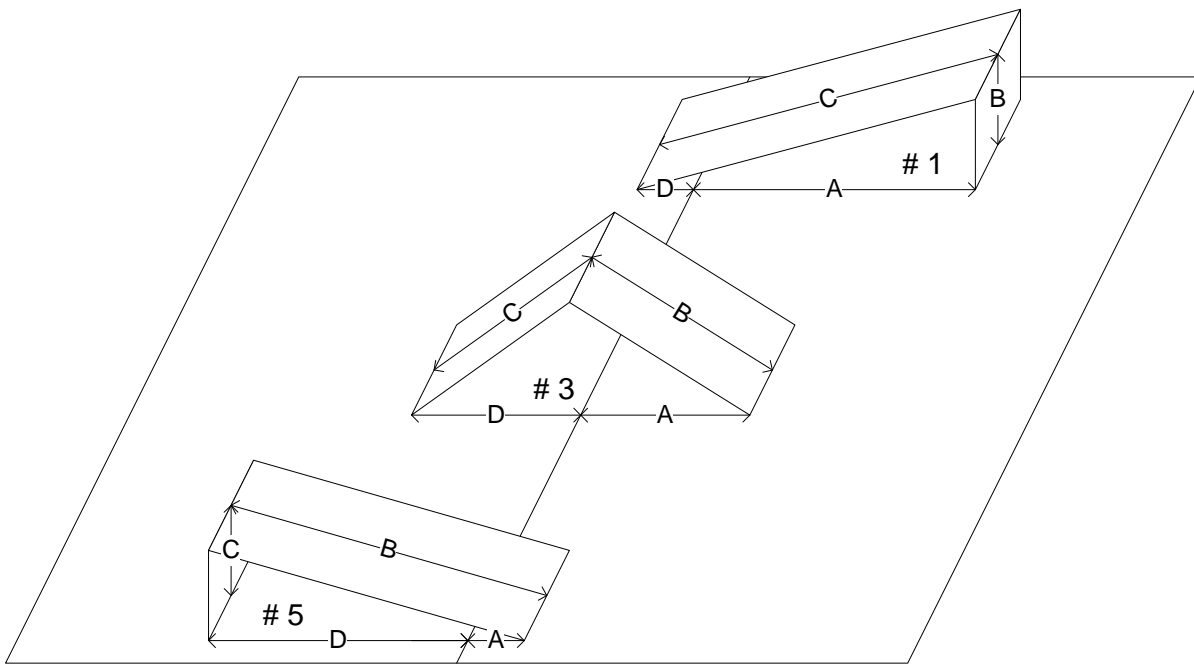

Figure 3: Pop-ups #1, #3 and #5 from the Left & Right experiment, with links labeled

Pop-up #	Left side		Right side	
	D	C	B	A
1	Taped near	Fold makes it longer	Fold makes it shorter	Taped far
3	Taped equal	Fold makes them equal		Taped equal
5	Taped far	Fold makes it shorter	Fold makes it longer	Taped near

Table 3: How the book adjusts the two sides of the pop-up, B & C

It seems that whatever we choose for A and D, when we tape the strip in, the book will “compensate” by adjusting B and C so that the left side C & D is similar to the right side A & B. In the next lesson, we will develop this conclusion further, by using measurements of A, B, C and D, and comparing the measurements on the two sides.

2. High and low: In this experiment, the two page positions are equal. There are several **controlled variables**:

- a. the two page positions are equal, so $A = D$,
- b. the strip is 12 cm. long, which makes $B + C = 12$ cm.

As we saw in the first experiment, the two links of the pop-up piece, B & C, will be equal when A and D are equal. Since B and C are equal, and they have to add up to 12 cm., each one has to be half of 12, so the result of a. and b. is

- c. $B = C = 6$ cm.

The **input variable** is one page position, let’s say A. The other page position (D) must equal A, so only there is only one independent variable. Students will probably notice that the pop-up rises higher above the page if both sides are taped closer to the gutter. You might ask them, so what **variable** changes as a result of moving the places where both sides are taped (page positions) closer to the gutter? The most obvious **output variable** is how high the fold line rises above the open book. When the book opens, it might look like in Figure 4. The height is labeled on Pop-up #3 in the diagram.

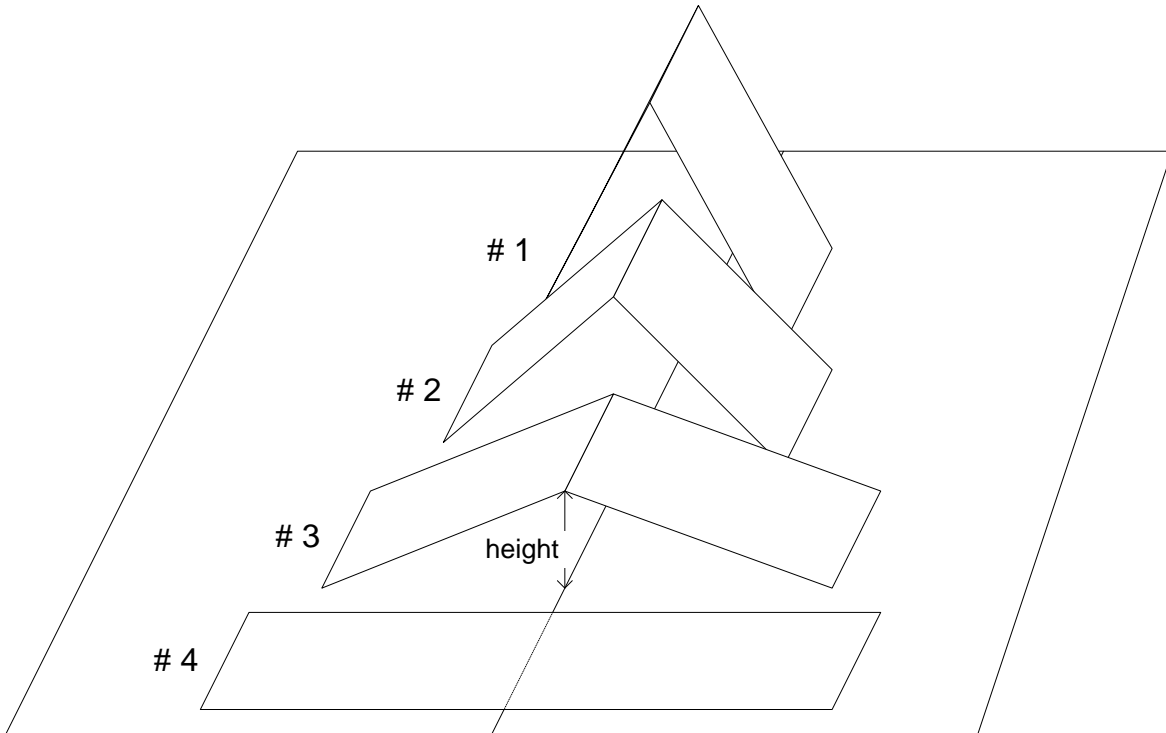

Figure 4: What changes when strips are taped near or far from the center?

Why does the height increase as the page position on either side decreases? To answer this requires a little plane geometry. Figure 5 shows a symmetric pop-up with links A & B labeled, as well as the height, which we'll abbreviate as H .

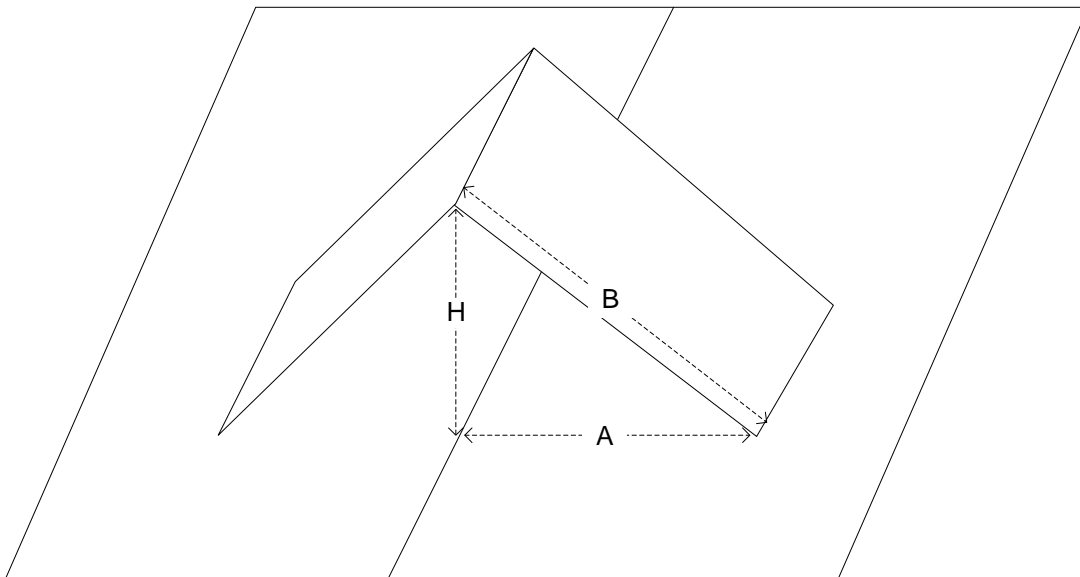

Figure 5: Height (H) and links A and B form a right triangle

From Figure 5, you can see that A, B and H form a right triangle. We have already explained why $B = 6$ cm. – it is half the total strip width, which was set to 12 cm. The Pythagorean Theorem tells us the relationship between the three sides of a right triangle (all distances in cm.).

$$A^2 + H^2 = B^2 = 36, \text{ because } B = 6. \text{ So } H^2 = 36 - A^2.$$

$$\text{Therefore, } H = \sqrt{36 - A^2}.$$

Notice that A^2 is subtracted from a number, so increasing A will reduce H and vice versa. In words, the further the page positions are from the gutter, the lower the pop-up will stand; the closer it is to the gutter, the higher it will be – just what we saw in the experiment!

Glossary

Asymmetry: Lack of symmetry in an object.

Controlled variable: A variable that is deliberately kept the same during an experiment, to see the effect of another variable.

Height: Distance from the base.

Input (independent) variable: Variable that is deliberately changed in the course of doing an experiment, to see what effect it will have on another variable – the output variable.

Output (dependent) variable: Variable that is expected to change as a result of changing the input variable.

Symmetry: A pattern that repeats itself, sometimes as a mirror image.

Variable: A property of an object or system that can change in the course of doing an experiment.

Lesson 5: The Pop-up Computer

Overview

In Lessons 3 and 4, we discovered that the pop-up book always seems to “know” where it “wants” to make the fold. Also, it follows some rules when it does so, such as “it always makes the fold on the far side.” In this lesson, students learn to predict where the fold will come out on the strip. To do so, they measure the four link lengths, discover a mathematical pattern that connects them, and write an equation expressing this pattern.

Materials

- ✂ Scissors, tape, ball-point pens, markers and rulers
- ✂ Parallel-fold Template, printed or photocopied onto 8 ½" x 11" cardstock.
- ✂ Science notebooks
- ✂ Folders containing previous work from Lessons 3 & 4.

Procedure

1. **The Pop-up Computer:** Review the previous two lessons. We’ve discovered that a pop-up book always “decides” where to make the fold in the pop-up piece. How does it make this decision? Actually, it solves a math problem when it makes the fold. For this reason, we call it “The Pop-up Computer.” In this lesson, we’ll find out what math problem the book is solving. That is, we’ll get “inside the mind of the Pop-up Computer.” Once we can predict where the pop-up will make the fold, we can make the fold in that place in advance, and the pop-up book will always “respect” the fold we made. To find out the math problem, we’ll have to make some measurements on our pop-up books. It won’t be hard, because there are rulers printed right on the template.

2. **Links and Hinges.** A hinge is a connection that allows one piece to rotate around another, along a straight line. Examples are door and cabinet hinges, the human knee and elbow, flaps on cardboard boxes, the hinge between the back and seat of a folding chair, etc.

Using pop-up books they have made in the previous two lessons, ask each student to identify the **hinges** in a pop-up. How many are there, and where are they located? They should emphasize each one using a marker. The result might look like in Figure 1.

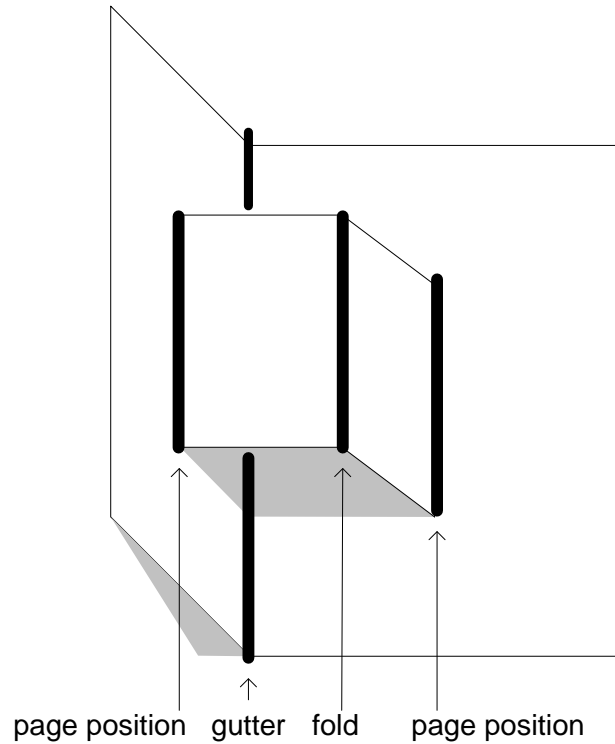

Figure 1: The four hinges of a pop-up

Next they should look for the four **links** – the flat pieces of paper that connect the hinges, and which the hinges allow to rotate. Using markers, they should label these A, B, C and D, starting at the gutter and going counterclockwise. Demonstrate these labels using a large drawing on chart paper or a large pop-up model, so everyone can see. Figure 2 shows the labeling.

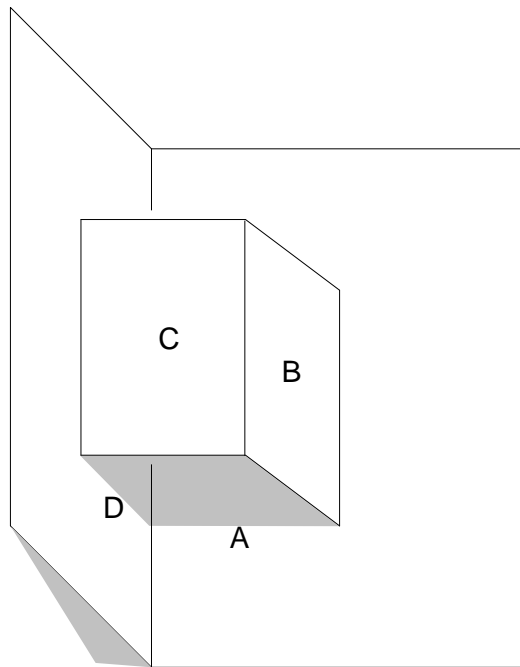

Figure 2: The four links, labeled A, B, C and D

3. Measuring link lengths. To find out the math problem the Pop-up Computer solves, the next step is to measure the four link lengths, A, B, C and D, shown in Figure 3 and Table 1. These lengths are the distances between hinges on each of the four links.

Length	Location	Distance Between	
A	Right side of book	gutter	right page position
B	Right side of pop-up	right page position	fold
C	Left side of pop-up	fold	left page position
D	Left side of book	left page position	gutter

Table 1: The link lengths of a pop-up

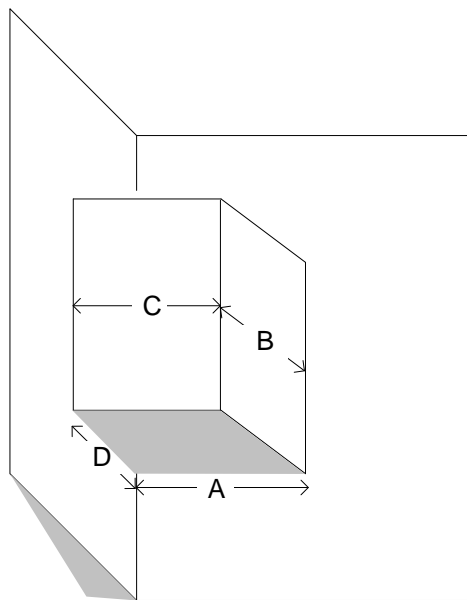

Figure 3: The four link lengths

To measure A, C and D, simply read the rulers printed in the book and on the strip. A and D show the distance from the gutter in the book, and C shows the distance from the left end of the strip – the page position – to the fold. However, B is a little bit harder, because the distance must be read from the fold line to the other end of the strip, which is not represented directly, and requires subtraction. Following is a mini-lesson that may be needed to address this issue:

Mini-Lesson for measuring link lengths on the strip

Cut a strip from the Template.

- ✂ How long is it?
- ✂ If this strip was taped into the book, which link lengths would it contain?
- ✂ What will these link lengths have to add up to?

Now fold the strip at the line numbered 5. Unfold it and mark the fold line with a marker. Then,

- ✂ Label the two link lengths that would be on the strip if it were taped into the book.

Figure 4 shows what it will look like.

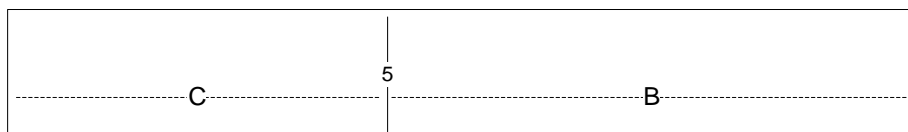

Figure 4: Strip folded at 5 cm., with link lengths B and C labeled

What are the link lengths B & C?

Many students will say that both B & C are 5 cm., because that's what the number says at the fold line. They couldn't be, because B and C have to add up to the total strip length, which is 12 cm., not

$5 + 5 = 10$ cm. C is indeed 5 cm., because the numbers start at 0 on the left end. But what is B? Help students see that $B + C = 12$ cm. We already know that C is 5 cm., so you can find B by subtracting this number from : $B = 12 - 5$ cm. = 7 cm.

4. Collecting and recording data. Ask students to number at least four pop-ups in a book they have made in the previous lesson, or just make a new one from another Template. Then they are to measure the four link lengths A, B, C and D on each of these pop-ups, and enter the data on the Worksheet.

5. Class discussion of the data. Ask a student from each group to provide a single row of data from their worksheet. Write the data on a Master Cass Data Table. Encourage students to report data that has different numbers from the ones already on the chart.

Scan each row quietly to verify:

$$A + B = C + D \text{ and } B + C = 12$$

As you look through the data, identifying valid data sets, ask the students: "What am I looking for in the data? How can I tell if the experiment was done correctly? What makes me so sure that some of the data doesn't fit?" Develop the idea that there are underlying principles that always seem to work – even if the data doesn't agree. A scientist looks at data with an eye to why something doesn't work out right, when they are convinced that it should.

If a row of data meets the tests, put a star next to it, and say, "That's good data." Enter data on the chart until you have about 5 or 6 rows of good data. Then ask students to look for patterns in the data. What were you looking for when you decided that data was "good?" If students have difficulty seeing the pattern, they can try to find it using Part B of the Worksheet. Once they have found the pattern, they should describe it in Part C.

At the end of the lesson, students should attach their worksheets to their Science Notebooks.

Name: _____ Date: _____

The Pop-up Computer

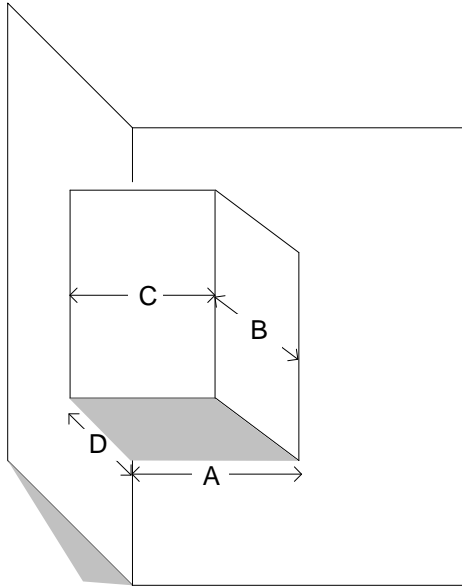

Key

Link	Location	Distance Between	
A	right side of book	gutter	right page position
B	right side of pop-up	right page position	fold
C	left side of pop-up	fold	left page position
D	left side of book	left page position	gutter

A. Data Table: Select four pop-ups you have already made using the Template. Label each pop-up with a number. Measure the four link lengths and enter the data in the table.

Pop-up #	A	B	C	D	Observations
1					
2					
3					
4					

Name: _____ Date: _____

The Pop-up Computer, continued

B. Class Data Table. After your class has shared its data, fill in A, B, C and D from other students. Use only data that your teacher described as "good data." Then look for patterns in the data. To do this, fill in the two new columns labeled A + B and C + D

A	B	C	D	A + B	C + D	Observations

C. Patterns in the data: What pattern do you notice in this data?

Outcomes

Students should learn that if the link lengths of a pop-up are measured correctly, $A + B = C + D$.

Assessment

- ✂ If the strip is folded in the middle, what will B and C be?
- ✂ If a pop-up is symmetric, which link lengths would have to be equal?
- ✂ Suppose a student reported this data: $A = 4$; $B = 7$; $C = 7$; $D = 2$. Is this good data? If not, what do you think went wrong?
- ✂ Suppose you fold the strip in the middle, and then tape it so $A = 4$ and $D = 2$. Will the book “like” the fold you made? If not, where will it make the fold?

Extensions

1. Find out what makes a pop-up stay inside the book, or stick out it, when the book is closed.
2. Find out what makes a pop-up stand up or lie flat when the book is open.

Troubleshooting

It is likely that some of the data will not satisfy the relationship $A + B = C + D$. There are several possible reasons for bad data:

1. **Failure to cut the strips properly.** Each strip should be approximately 12 cm. long. There are marks at 1 through 11, but not at 0 and 12. Students may have cut them elsewhere besides 0, but assumed the numbers were valid anyway.
2. **Students count lines rather than boxes on the rulers.** This is a classic measurement problem. Review the use of a ruler.
3. **Failure to read B and C independently.** Students may always show the same number for B and C. This is the subject of the Mini-Lesson, “Measuring Link Lengths” in Procedure Step 3.
4. **The actual hinge is not located at the measured page position line.** Recall that the four significant lines in a pop-up are the axes of hinges, around which the links can rotate. If too little tape is used, it may lift off the book, and a new fold may form in the tape itself (Figure 5 (a)). If too much tape is used, the pop-up may form a new hinge line, because the tape won’t allow a fold at the measured line (Figure 5 (b)). Suggest to students that they measure from where the hinge actually formed, rather than where they thought it would form!
5. **The page position line is not parallel to the gutter.** In this case, *no* measurement of the link lengths can be valid, because these will vary along the width of the strip. See Figure 5 c). Encourage students to check whether the page position lines are parallel to the gutter, and ruler lines in the book.

6. **Round-off error.** If none of the above issues applies, but the results are still off by 1 or 2 cm., the problem may simply be due to round-off. Students may count only whole numbers of cm. Encourage them to estimate and use half-centimeters.

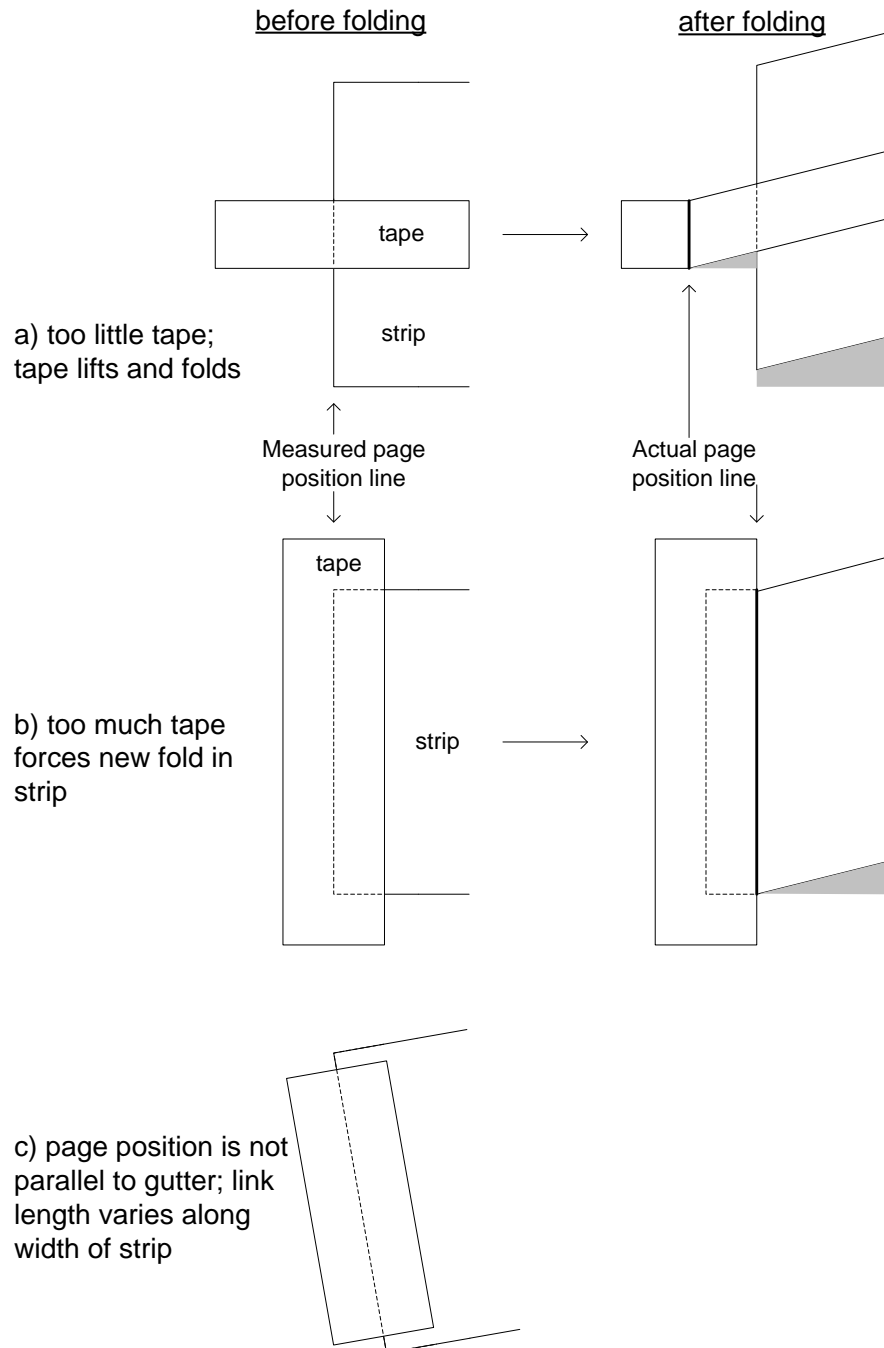

Figure 2: Taping that can lead to invalid measurements

Lesson 6: Where does it Hide?

Overview

This lesson develops an explanation for the **Pop-up Computer** result in Lesson 5. First, students predict how the pop-up will fit inside the book when it is closed; then they find out by assembling a pop-up inside a clear folder. The results will probably surprise them (and you)! This information leads to a visual picture of why $A + B = C + D$.

Materials

- ✂ See-thru Book
- ✂ Science Notebooks
- ✂ Scissors, tape, ball-point pens and rulers
- ✂ Parallel-Fold Template

Procedure

1. **When does it make $A + B = C + D$?** Review the data from Lesson 5. We found out that $A + B = C + D$. Ask the class:

- ✂ When does the pop-up book make this happen?
- ✂ If $A + B$ does not $= C + D$, when will the book “have its way?”

2. **Where does it hide?** The book enforces the rule $A + B = C + D$ whenever it closes. To see why the rule is true, we will need to know out more about what happens when the book is closed. In the middle column of the Worksheet, ask students to predict where three different pop-ups will “hide” inside the book when it is closed. They do so by drawing the shape and location of the pop-up piece inside the closed book. Once they have done so, ask for ideas about how they could check if they were right or not. They can’t check their answers directly, because they can’t see inside the closed book! (You might point out that Superman would not have this problem.) Is there a book that they can see inside?

Then provide each student with a See-thru book. They should assemble each of the three pop-ups inside the See-thru book, close it, and look to see if the pop-up piece is where they predicted it would be on the Worksheet.

Science Notebook:

1. **Describe** what you did. How did you make a pop-up in the see-thru book? What were you looking for? What did you expect to find?
2. **Discuss** their results. What happened? Did the results come out the way you expected? What did you learn from this experiment?

3. **Explaining where it hides:** Conduct a whole-class discussion based on what students have written in their notebooks. Provide time for students to try to figure out for themselves why the pop-up hides where it does. Here are some scaffolds for helping them figure this out.

- ✂ What does each page of the book do as the book is closed?

- ✂ Where is the gutter after the book is closed?
- ✂ What does each page position line do as the book is closed?
- ✂ What direction does the pop-up fold line travel as the book closes?
- ✂ What will happen to the four links, A, B, C & D, as the book closes?

Science Notebook:

1. Why do you think the pop-up moves to the right when you close the book? Why doesn't it stay in the center?
2. What is making it move? What parts of it can't move and what parts can?

4. Why does $A + B = C + D$? Inside the see-thru book, label link lengths A, B, C and D. If transparency markers are not available, lengths A and D can be written on masking tape, and attached to the folder.

- ✂ Look at the locations of A, B, C and D when the book is closed. Which ones are on the bottom? Which ones are on top? Make a drawing showing A, B, C and D.
- ✂ Where do A and B start and stop? Where do C and D start and stop?
- ✂ If two lines lie one on top of the other, and start and stop in the same place, what do we know about them?
- ✂ What can we conclude about $A + B$ and $C + D$?

Science Notebook:

1. **Describe** what you did. What did you label inside the see-thru book? What were you looking for?
2. **Discuss** the results. What did the clear folder show about the relationship among A, B, C & D?
3. **Explain** the results. Why do you think $A + B = C + D$? Will this always work?

Outcomes

The learning outcomes are listed according to the four sections of the Procedure:

1. **When does it make $A + B = C + D$?** $A + B$ must = $C + D$ for the book to close.
2. **Where does it hide?** The pop-up piece always moves to the right as the pop-up closes. It never stays above the gutter.
3. **Explaining where it hides:** As the book closes, the left page folds over the right. The left page position moves with it. The gutter and the right page position don't move. The fold follows the left page position and moves even further to the right.
4. **Why does $A + B = C + D$?** When the book is closed, A and B will be on the bottom and C and D will be on the top. Both extend from the gutter to the fold. Since they start and end at the same places, and one is directly on top of the other, they must have the same length. Therefore $A + B = C + D$.

Assessment

- ✂ What would happen to your book if $A + B$ did not = $C + D$?
- ✂ Which of the hinge lines move and which ones don't move as the book is closed? What is holding those that don't move? What is forcing those that do?
- ✂ When the book is closed, why doesn't the pop-up stay above the gutter? What is making it move? Where does it go?
- ✂ Using the See-thru book, explain why $A + B = C + D$.

Name: _____ Date: _____

Where does it Hide?

Directions:

1. **Examine** the pop-up in each row on the left. It is assembled so the pop-up piece lies flat when the book is open.
2. **Imagine** that the book is closed by turning the page on the left side.
3. In each row, **predict** where the pop-up piece will hide inside the book when it is closed. Draw your prediction in the middle rectangle.
4. **Check** each prediction by making the pop-up inside the see-thru book.
5. In the column on the right, **draw** where it actually went.

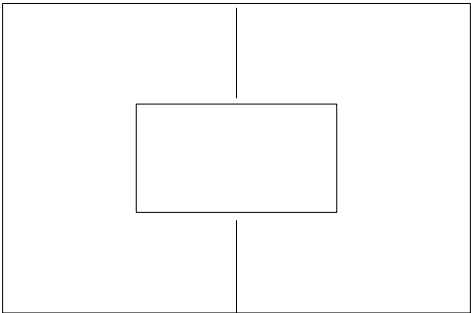
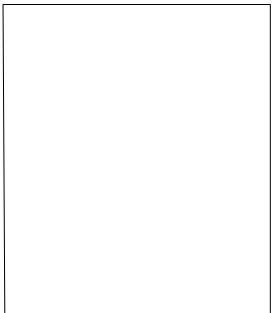
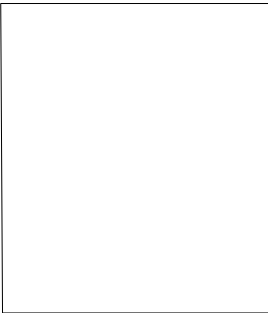
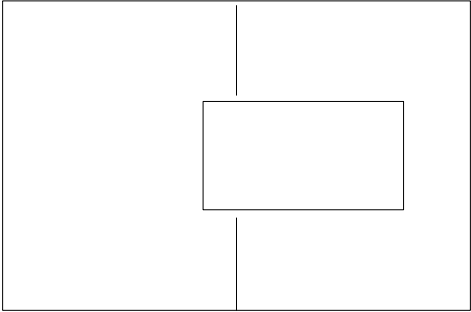
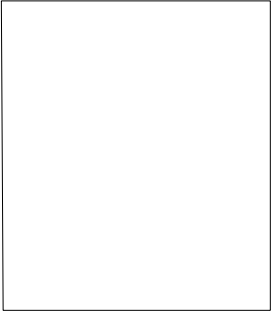
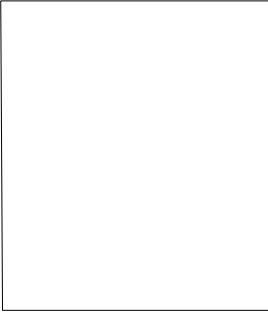
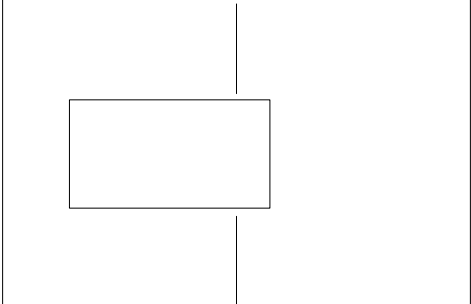
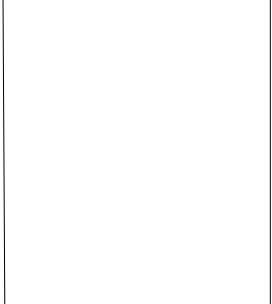
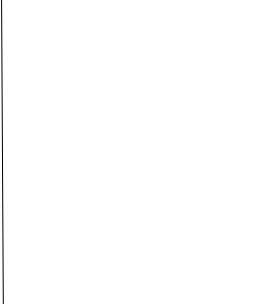
	<u>Open</u>	(Predicted) <u>Closed</u>	(Actual)
a)			
b)			
c)			

Extensions

1. Write a formula that has to be true for the pop-up to stay inside the book when the book is closed.
2. Write a formula that has to be true for the pop-up to lie flat, when the book is open.
3. How can you make the pop-up and book look like a rectangle, parallelogram, rhombus or square from an edge view?

Troubleshooting

1. Where does it hide? Most people, including most adults, get the Worksheet exercises wrong. It is essential that you **try this exercise first**, before you give it to the students to do. It is likely that the results will surprise you as much as the students!

Students may have difficulty in making their pop-ups inside the See-thru book look like the ones on the worksheet. They don't need to be exact. The predictions are intended to be approximate. The pop-up in row a) should be approximately symmetric; row b) should have a larger page position on the right than on the left ($A > D$), and the opposite should be true in row c) ($A < D$). The pop-ups should be assembled without first folding the strip. Lift each one slightly as you close it to make sure the fold is pointing towards you.

2. Explaining where it hides. The explanation depends on which hinge lines are moving and which are not as the book closes. To keep track of these, it may be helpful to label them on the See-thru Book, as in Figure 1. Labeling the hinge lines can also make it easier to identify the link lengths A, B, C and D for the next activity.

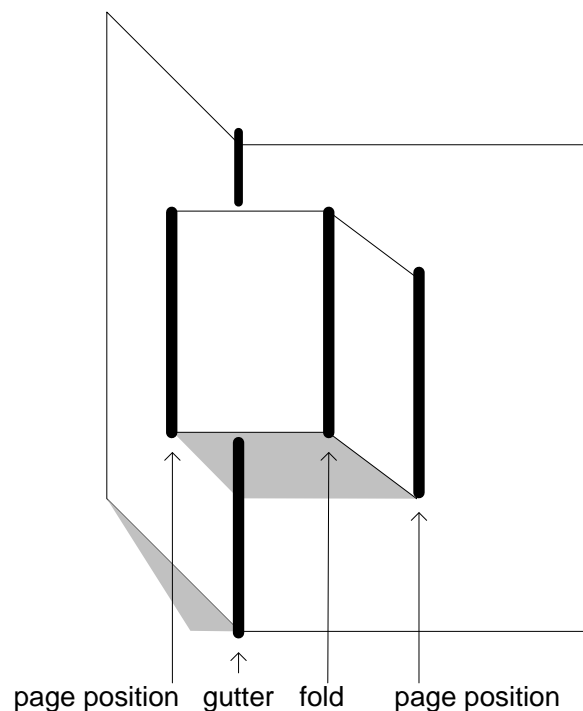

Figure 1: The four hinge lines

3. Why does $A + B = C + D$? Label A, B, C and D clearly, so each one can be seen through one of the clear covers of the See-thru book. A and B should be visible side-by-side inside the right cover, and C and D should be visible side-by-side inside the top cover. A and B will then be immediately below C and D, and the two sums will be equal. To recognize this, it is necessary to visualize the top and bottom of the book simultaneously. Students will have to flip the book over several times in order to realize that $D + C$ is right on top of $A + B$, and they both start and end in the same places.

Technical Background

1. When does it make $A + B = C + D$? Until the book actually closes, it doesn't matter what A, B C and D are. The book forces the fold between B and C when it closes. This is the fold that enforces the rule $A + B = C + D$, which is the condition for the book to close.

2. Where does it hide? Figure 2 is an Answer Guide to the Worksheet, which shows the approximate location of the pop-up in each of the three cases. Most people predict that the pop-up will remain next to the gutter when the book closes. The next activity helps to explain why it doesn't.

3. Explaining where it hides. Five questions are provided in the Procedure as scaffolds for understanding why the pop-up hides where it does. These are repeated with detailed discussion below:

✂ **What does each page of the book do as the book is closed?**

The left page folds over until it is sitting directly above the right page, which never moves. Therefore, anything attached to the left page will move to the right, while anything attached to the right page will stay in the same place.

✂ **Where is the gutter after the book is closed?** The gutter is along the right page, so it will not move.

✂ **What does each page position line do as the book is closed?** The left page position will have to move with the left page, but the right page position will not be able to move, because it is attached to the right page.

✂ **What direction does the pop-up fold line travel as the book closes?** The fold line separates the left and right sides of the pop-up. It will move to the right, because it will be forced to by the left page position.

✂ **What will happen to the two pop-up links, A, B, C & D as the book closes?** Let's go through them one-by-one. A is on the right page, so it won't move at all. B is between the right page position, which doesn't move, and the fold line, which moves to the right. So B has to flip around the right page position and follow the fold as it moves towards the right edge of the book. C will follow B and wind up more-or-less on top of it, because they are joined at the fold. D flips over too, as the left page rotates around the gutter, bring D pretty much above A. This information is summarized in Table 1.

Link	Motion of its hinges		Motion of link
A	<u>gutter</u> does not move	<u>right page position</u> does not move	A (right page) does not move
B	<u>right page position</u> does not move	<u>fold</u> moves to the right	B flips over right page position and follows fold line to edge of right page
C	<u>fold</u> moves to the right	<u>left page position</u> moves to the right	C follows left page and moves above B
D	<u>left page position</u> moves to the right	<u>gutter</u> does not move	D (left page) flips around gutter and moves above A (right page)

Table 1: How the links move when the book is closed

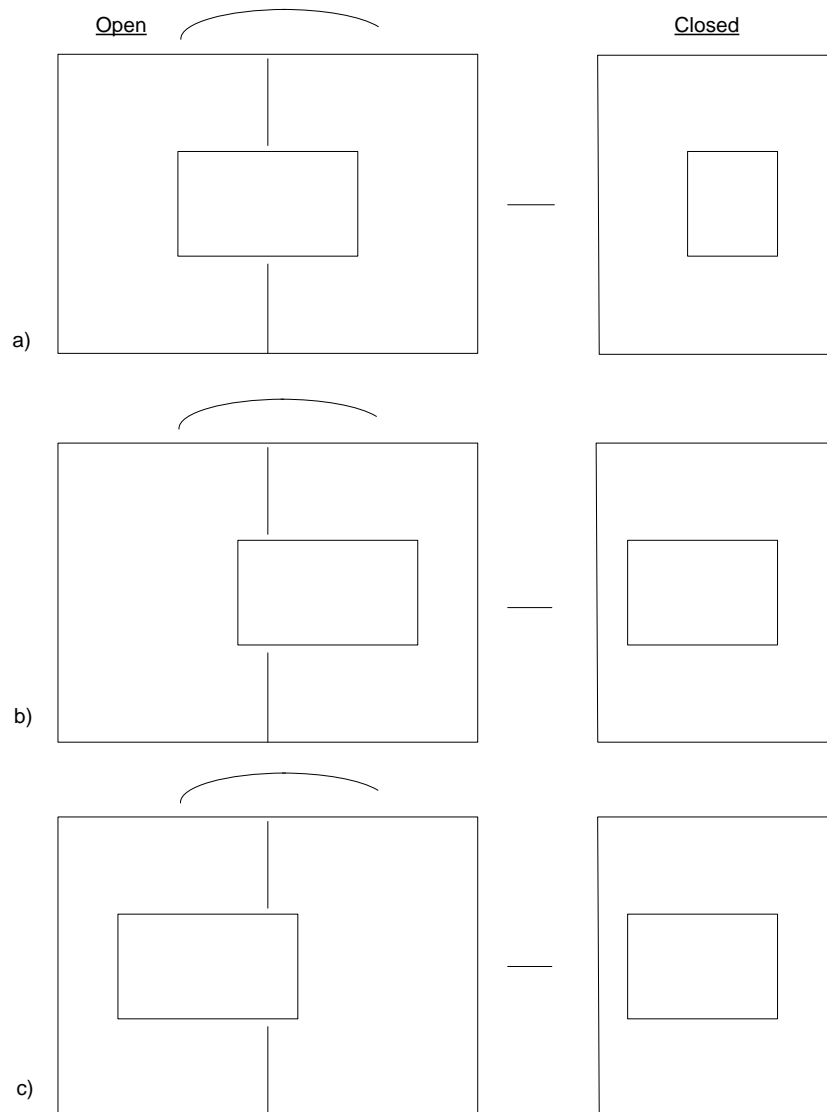

Figure 2: Lesson 6 Worksheet Answer Guide

4. Why does $A + B = C + D$? Figure 3 shows the See-thru book from a top and bottom view, with all four link lengths labeled. From the figure, it should be clear that A & B will lie side-by-side on the bottom and C & D will lie side-by-side on the top. To see the bottom view, look at the folder from underneath. If you flip it over, you'll see a mirror image. Both distances, $(A + B)$ and $(C + D)$, extend from the gutter to the fold line, and both are straight lines, so the two distances must be the same.

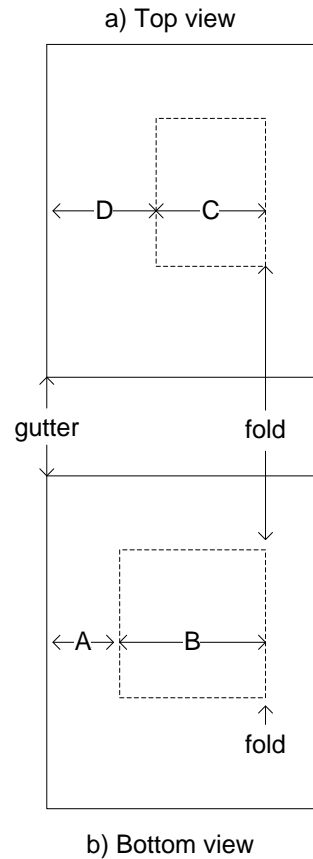

Figure 3: Inside the see-thru book

Extensions:

1. What has to be true for the pop-up to stay inside the book, when the book is closed? To answer this make three pop-ups inside the See-thru Book that do three different things when the book is closed:

- a) One that stays inside;
- b) Another that just touches the right edge; and
- c) A third that sticks out.

Figure 4 shows a top view of the See-thru Book in all three cases. Link lengths C and D are labeled, as well as the width of the book W.

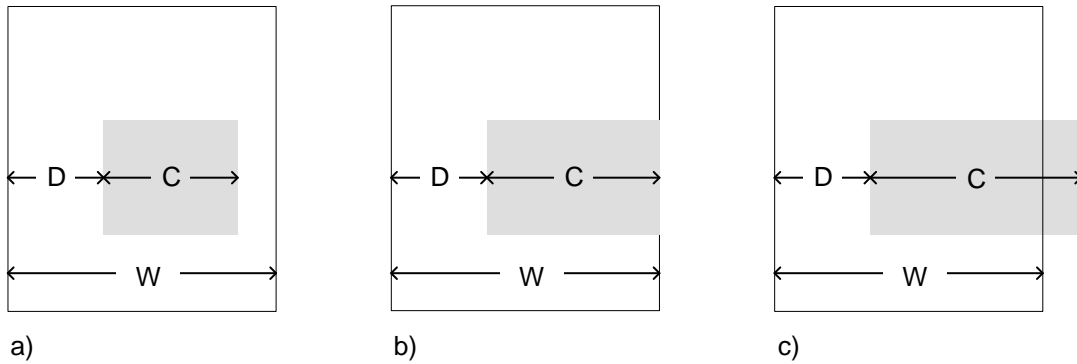

Figure 4: Top view of the see-thru book: a) pop-up stays inside; b) just touches or c) sticks out
 From the diagram, the conditions for the three cases are:

- a) The pop-up will stay inside if $C + D$ is less than W .
- b) The pop-up will just touch the right edge if $C + D = W$.
- c) The pop-up will stick out if $C + D$ is greater than W .

Because the book closes in each case, $A + B = C + D$, so you can substitute $A + B$ for $C + D$ in each statement.

2. What has to be true for the pop-up to lie flat, when the book is open? Figure 5 shows a such a pop-up, with link lengths labeled.

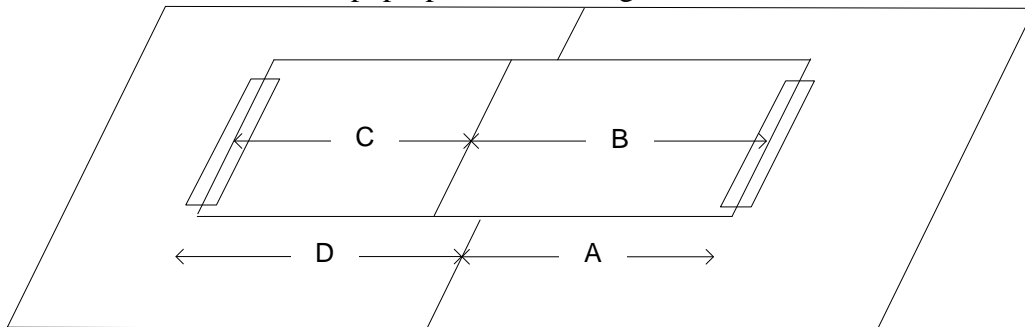

Figure 5: Link lengths labeled on a pop-up that lies flat when book is open

Because the pop-up piece is lying flat, it bridges the same distance as the distance between page positions. The distance between page positions $A + D$ must therefore be equal to the strip length, $B + C$:

$$A + D = B + C$$

The book also closes, so this new condition has to be true **in addition to** the condition for closing:

$$A + B = C + D$$

In algebra, these two equations are called simultaneous linear equations. Using algebra or geometry, you can show that the solution of both equations simultaneously is:

$$A = C \text{ and } B = D$$

3. How can you make the pop-up and book look like a rectangle, parallelogram, rhombus or square from an edge view?

Any quadrilateral (four-sided shapes) with $A = C$ and $B = D$ is a parallelogram. Therefore, a pop-up that lies flat when the book is open will look like a parallelogram when the book is in any other position. See Figure 6.

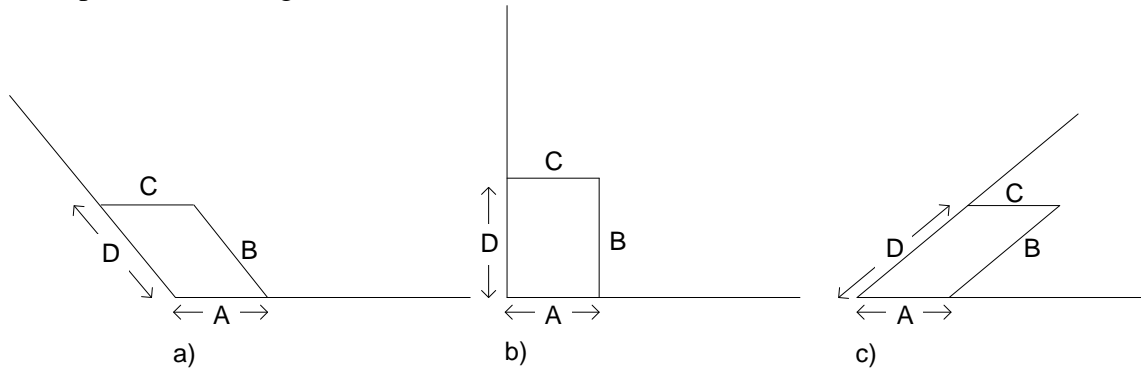

Figure 6: Edge-view of a pop-up when $A = C$ and $B = D$

A rectangle is just a special case of a parallelogram when all four angles are 90° , as in Figure 6 b). A rhombus is a special case of a parallelogram that has all four sides equal, $A = B = C = D$. A square is a special case of a rhombus that has all four angles at 90° . The various cases are summarized in Table 2.

Condition	Book closes: $A + B = C + D$	Pop-up lies flat when book open: $A + D = B + C$	Symmetric: $A = D$	Book half-open: each inside angles is 90°
Quadrilateral				
Parallelogram	yes	yes		
Rectangle	yes	yes		yes
Rhombus	yes	yes	yes	
Square	yes	yes	yes	yes

Table 2: Pop-up shapes from an edge view

Glossary

Parallelogram: Quadrilateral with opposite sides parallel

Quadrilateral: Any four-sided shape

Rectangle: Parallelogram with all four angles = 90°

Rhombus: Parallelogram with all four sides equal

Square: Rhombus with all four angles = 90° ; rectangle with all four sides equal

System of simultaneous equations: Multiple conditions that need to occur together

Lesson 7: Stair-step Pop-ups

Overview

The pop-ups we have made so far were attached directly to the book. Pop-up constructions can be more complex than this. This lesson explores “Stair-step” pop-ups, which are parallel folds built onto other parallel folds. Through making these, and studying their properties, students are introduced to systems concepts and geometric forms.

Materials

- ✂ Scissors, tape, ball-point pens and rulers
- ✂ Parallel-Fold Template
- ✂ Science notebooks

Procedure

1. **Systems.** In a whole-class discussion, develop or review the **systems concepts: input, output, system and subsystem.**

Ask students to complete Worksheet 1. In Part A, they identify the inputs and outputs of some common systems, and then they add some of their own choice. Prompt them to focus on the **actions** that happen at the inputs and outputs, rather than the **places** where these happen.

After students have completed their worksheets, conduct a whole-class discussion of each part.

2. **The Stair-step Pop-up.** How one pop-up make a second pop-up work? To find out, have students begin by making a simple pop-up, with only one pop-up piece, using the same technique as in Lesson 3. To maximize the motion, the strip should be taped in flat, with no arch, before closing the book and forcing the fold to form. Because the strip is initially taped in flat, it will always lie flat when the book is fully open, as in pop-up #4, Figure 6, Lesson 4. Here, the strip should not be taped in symmetrically. See Figure 2(a) and (b).

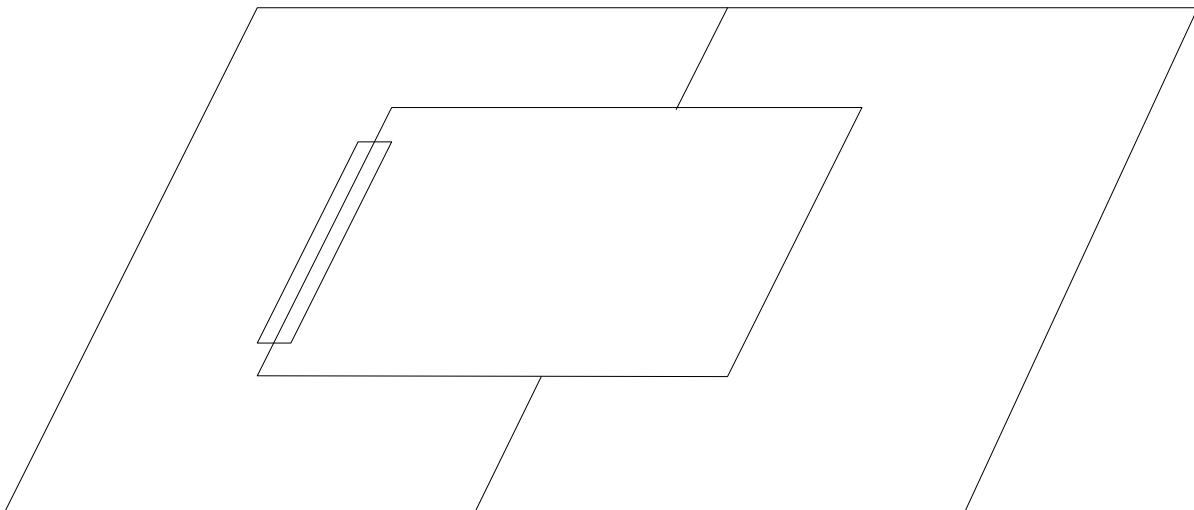

Figure 2(a): Making a pop-up that will lie flat when the book is fully open

After the book is closed, and then opened again, it will create a fold line in the pop-up:

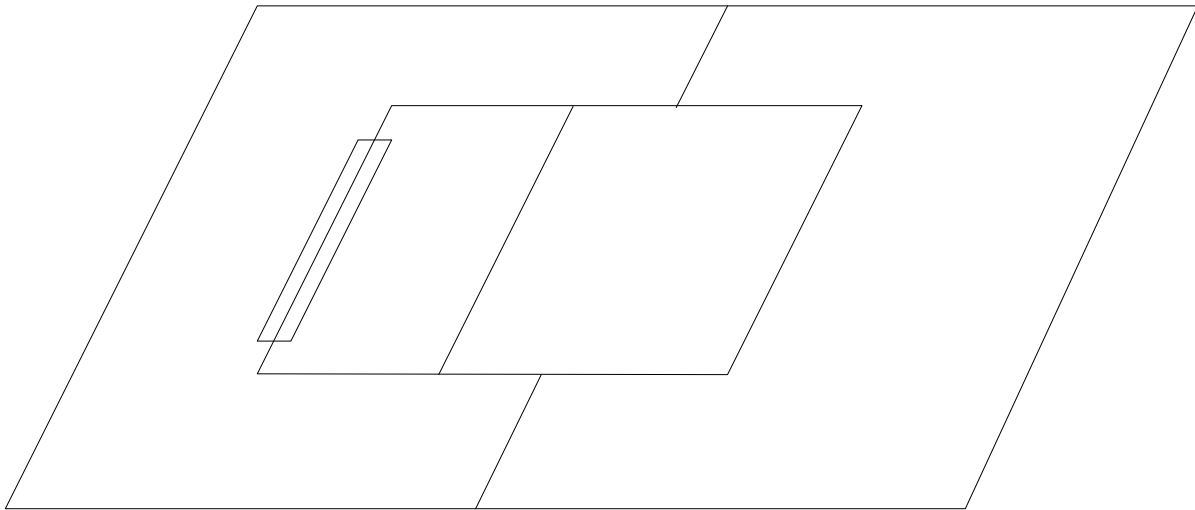

Figure 2(b): Pop-up after fold line has been formed

The next step is to add another pop-up to the first one, using the first pop-up as the “book” for the second. (One student called the first pop-up the “mini-book.”) This is done following the same procedure as before, **except that the new pop-up piece is taped across the page position rather than the gutter.** Figure 3(a) shows the second pop-up piece taped across the right page position of the first, before the second pop-up has created its fold. When they fold the book the second time, they should remember the **TIP** at the top of this page: pull up gently on the new pop-up to make sure it folds outward. The result of creating the second fold is shown in Figure 3 (b).

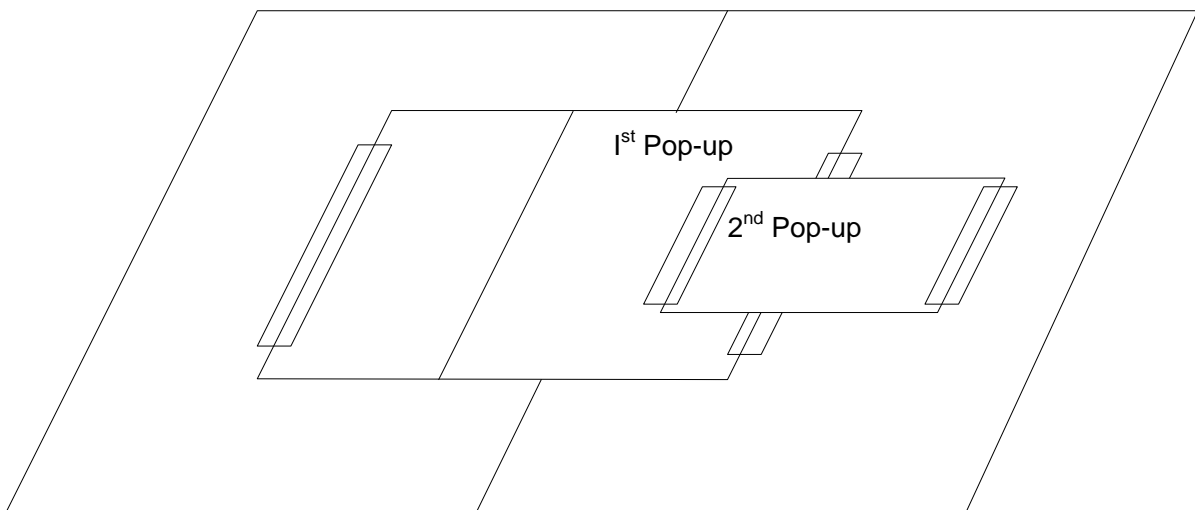

Figure 3 (a): Second pop-up taped in place, before closing the book the second time

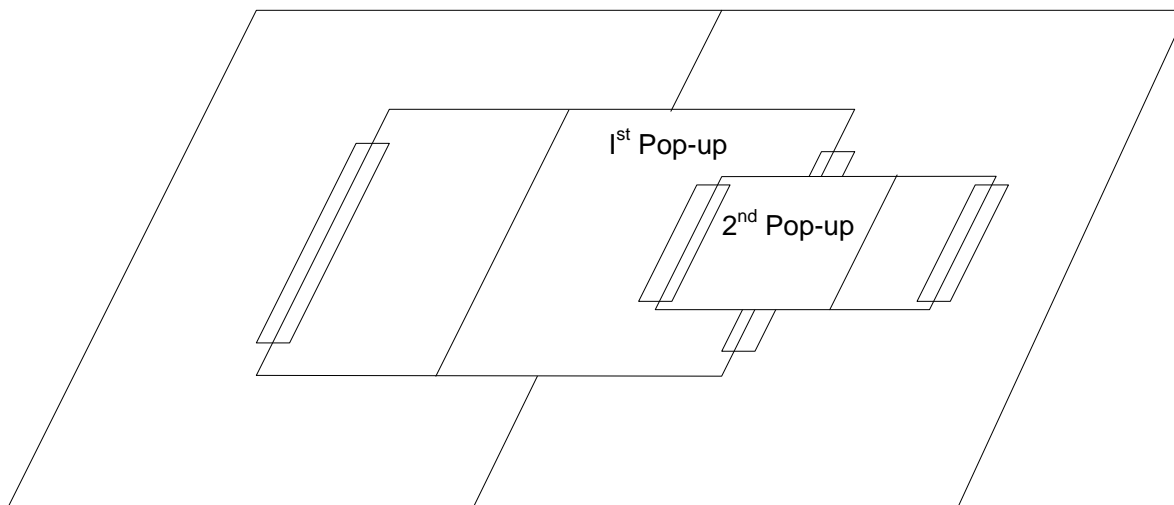

Figure 3 (b): After closing & opening again, a fold is seen in the 2nd pop-up

3. Edge views. Encourage students to experiment with this construction. Look at it from an edge view in the $\frac{3}{4}$ -, $\frac{1}{2}$ - and $\frac{1}{4}$ -open positions. On Worksheet 2, they should draw what the pop-up pieces look like in each position. What do they notice about it?

4. System diagram. At the bottom of Worksheet 2 are some prompts leading to a system diagram for the stair-step pop-up. How is this system different from the simple pop-up?

Outcomes

Through this lesson, students should develop the following conclusions:

- ✂ A system has an input and an output. A pop-up is a system whose input is opening or closing the book, and whose output is the resulting motion of the pop-up. From an edge view of a stair-step pop-up, you see similar shapes repeated, from one pop-up to the next.
- ✂ The shapes change from a rhombus to a rectangle and back to a rhombus as you open and close the book.
- ✂ A stair-step pop-up is a more complex system than a simple pop-up, because the output of one pop-up piece is the input to the next one.

Assessment

- ✂ What are the input and output of a pop-up if you move the right page instead of the left?
- ✂ How could you make a pop-up that has a square inside? How would you have to hold the book to see the square?
- ✂ How could you make a pop-up with **three** steps instead of **two**? Draw its system diagram.

Draw a system diagram for two pop-ups that are both attached directly to the book, such as two of the strips in Lesson 4. Explain how and why it looks different from the system diagram of a stair-step pop-up.

Name: _____ Date: _____

Worksheet 1: Inputs, Outputs and Systems

Key

Input = Action you take to make it work

Output = Result you look for due to your action

A. For each system 1-4, fill in the input and output. Then add two more

	System	Input	Output
1	Video game		
2	Scissors		
3	Telephone		
4	Pencil sharpener		
5			
6			

B. The drawing below shows a System Diagram. Label the arrows and box with the terms that fit: **Input**, **Output** and **System**.



C. What is the input to a pop-up book or card? _____

D. What is the output of a pop-up book or card? _____

Name: _____ Date: _____

Worksheet 2: The Stair Step Pop-up

What do you notice about the new pop-up you have made ?

Draw in all the inside parts from an edge view in the $\frac{3}{4}$ -, $\frac{1}{2}$ - and $\frac{1}{4}$ -open positions:

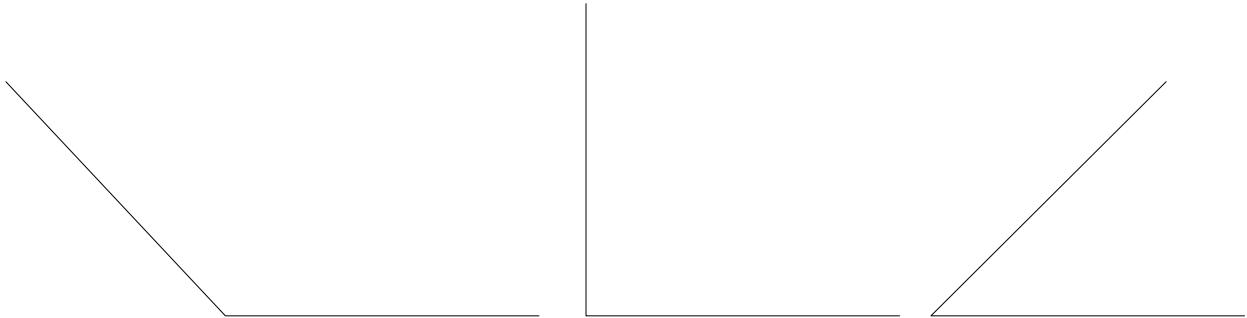

What do you notice about these shapes? _____

3. Stair step pop-up. What is the input of the first pop-up? _____

What does the second pop-up "think" is its "book?" _____

In the space below, draw a system diagram for a stair-step pop-up.
Label all boxes and arrows.

Troubleshooting

If either of the strips doesn't pop up, it is probably because the fold is folding inwards (towards the book) rather than outwards (towards you). To make the fold point towards you, pull the strip gently outwards as you begin to close the book. In a stair-step pop-up, you may need to do this with both strips.

Technical Background

1. Systems. With a little help, students should recognize that the inputs to a video game are through the controls. The actions might include pushing buttons, moving a joystick or turning a trackball. The outputs are the sound effects and motions of figures on a screen. Wii systems often have a wider range of inputs, such as dancing, playing a musical instrument or using fitness equipment. The input to a scissors is moving the handles, and the output is the motion of the blades, or the cutting of the paper. The input to a telephone used to be either pushing buttons (dialing) or talking, and the output was sound, but current phones often include cameras, video games, the Internet, etc. In a mechanical pencil sharpener, the input was turning the rank; electric pencil sharpeners are activated by simply inserting the pencil. Both have the same output: sharpening the pencil. Students are likely to come up with other examples, such as the computer, whose input includes the motion of the mouse.

The input to a pop-up mechanism is the opening and closing of the book. The output is the motion of the pop-up piece itself. These relationships are expressed in Figure 4.

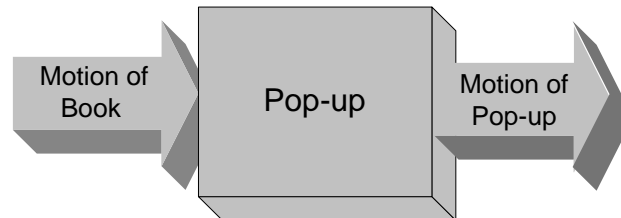

Figure 4: System diagram of a simple pop-up

3. Edge view. Figure 5 shows the half- and quarter-open positions. Viewed from the edge, the shapes inside the two pop-ups are parallelograms, which become rectangles when the book is half open. Why do the pop-ups maintain these shapes? They were assembled with each pop-up piece flat when the book is open. As a result, $A = C$ and $B = D$, which means that the shapes have to be parallelograms. See Technical Background for Extension 3, Lesson 6.

4. System diagrams. The key to making the system diagram for the Stair-step Pop-up is to recognize the input of each of the two pop-ups. The first pop-up is controlled by the book, but the second pop-up is attached to the book only on one side. Its left page position is on the first pop-up. Therefore the input to the second pop-up is really the first pop-up. This leads to a system diagram like in Figure 6.

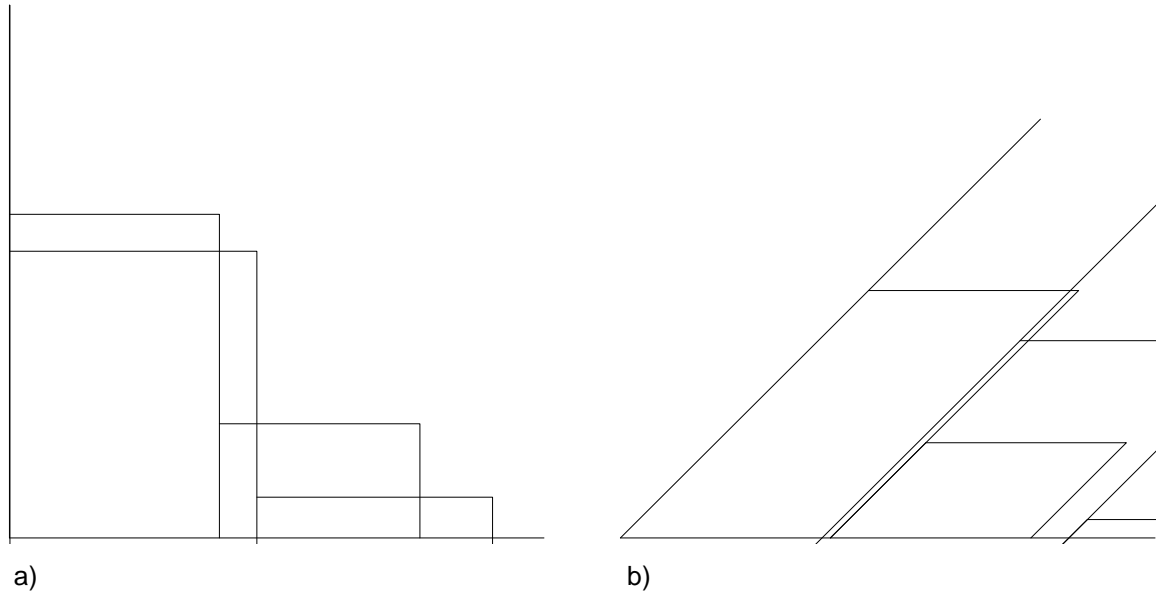

Figure 5: Edge view of stair-step pop-up in a) half- and b) quarter-open positions

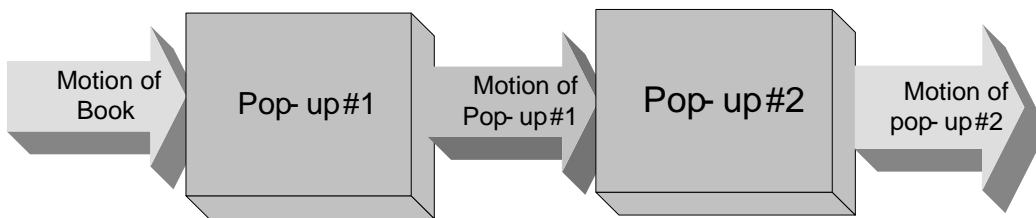

Figure 6: System diagram of a Stair-step Pop-up

Figure 6 is more complicated than the system diagram of a simple pop-up (Figure 4), because each of the two pop-ups could be a system by itself. Combined together in the same system, each of these pop-ups constitutes a **subsystem**.

If two pop-ups are assembled by attaching each one directly to the book on both sides, as in Figure 7, there will again be two subsystems, but they will not operate like a stair-step pop-up.

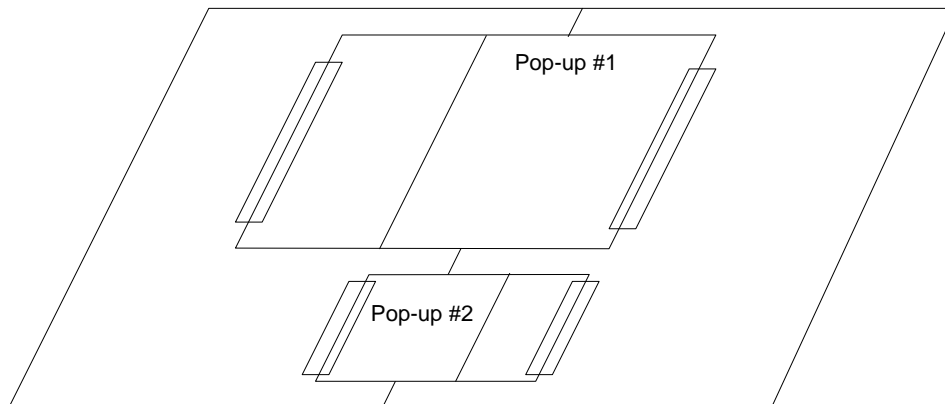

Figure 7: Two pop-ups operated directly by the book

The reason is that they both receive their inputs directly from the book, not one from another, as in the stair-step. Therefore, the system diagram is different.

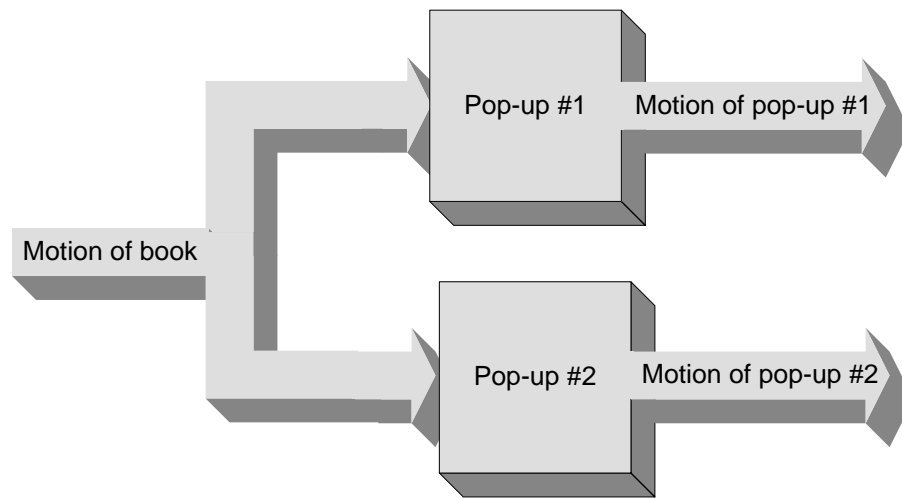

Figure 8: System diagram for pop-ups in Figure 7

The arrangement in Figures 7 and 8 is called a **parallel connection**, because both subsystems receive the same input. The stair-step pop-up in Figures 3 and 6, on the other hand, is a **series connection**, because the output of one is the input to the next. These terms have the same meaning here as in electric circuits. Disconnecting one bulb in series with others, as in some Christmas tree lights, will make the others go out. However, disconnecting a bulb that is in parallel with others, as in the lights above a bathroom cabinet, will have no effect, because all are attached directly to the same power source. Similarly, disconnecting Pop-up #1 in the series connection of Figure 3 or 6 will disable Pop-up #2, but have no effect on Pop-up #2 in the parallel connection of Figures 7 and 8.

Glossary

Compound system: A system consisting of more than one subsystem.

Input: The action you have to take to operate a system

Output: The result of applying the input to a system

Parallel connection: System arrangement in which two subsystems have the same input

Series connection: System arrangement in which the output of one subsystem is the input to another

Subsystem: Part of a system that could be a system in itself

System: A collection of parts that function together as a whole, operated by an input and resulting in an output

System Diagram: Block diagram showing relationships among inputs, outputs and subsystems

Lesson 8: How they Move

Overview

All of the pop-ups we have studied so far produce motion across the gutter, but not along it. Many of the pop-ups in commercially made books and cards can also produce motion along the gutter – up and down if the book is held upright. This unit explores this second type of pop-up mechanism, and compares it with the first. Students first compare these two types, by sorting pop-ups according to the direction of motion. They then explore the differences in construction.

Materials

- ✂ **Assorted pop-up books and cards**, including pop-ups already made by students, **simple** pop-ups in commercially made books and cards, and a few **intermediate** pop-ups.
- ✂ **Post-its™** and **scissors** for making flags
- ✂ **Science notebooks**

Procedure

1. Dimensions and directions of motion. Distribute sample pop-ups, including commercially made books and cards, as well as pop-ups made by students. Students will be looking at how the fold line moves as the book opens and closes. To bring out the motion, they should make flags from a Post-It™ (Figure 1) and attach one to each pop-up along the fold line, as in Figure 2.

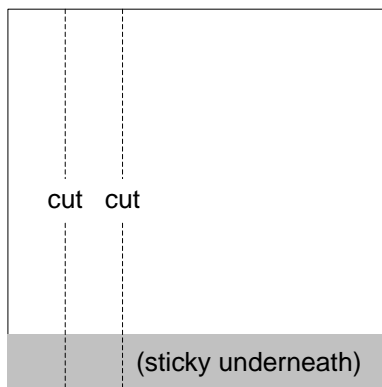

Figure 1: Cutting two strips from a Post-It™ for use as flags

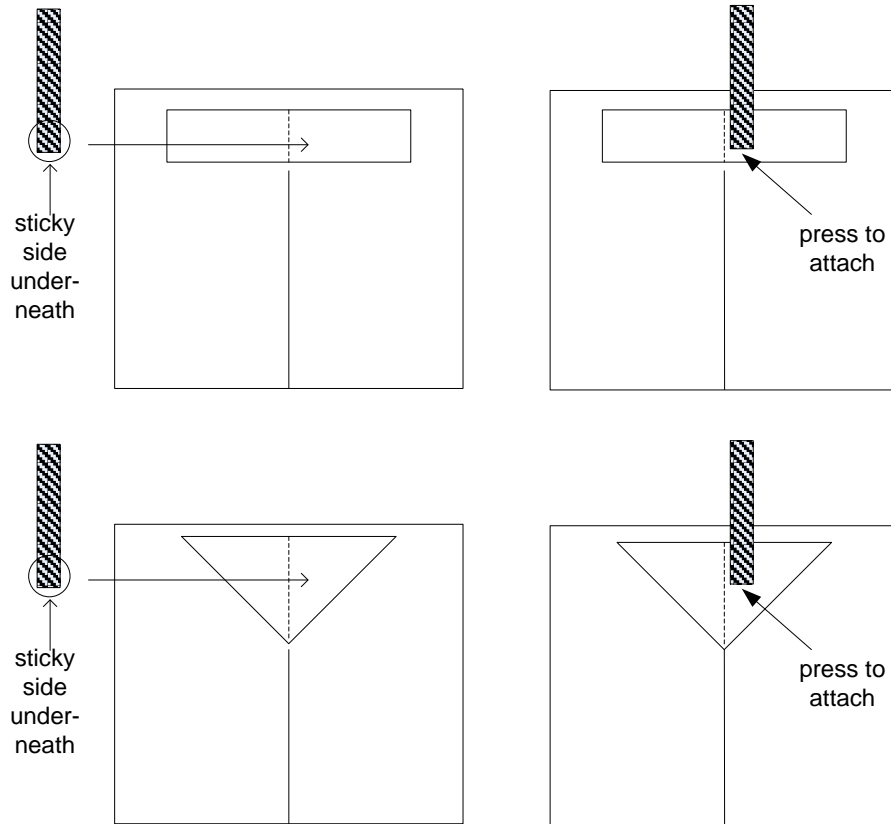

Figure 2: Attaching a flag

After they have experimented with the pop-ups for a few minutes, introduce three **dimensions** of motion. Each dimension is a line along which motion could go in either **direction**. These dimensions and directions will be easier to talk about if everyone holds and operates the book the same way. Figure 3 shows a standard way of looking at a book vertically, with one page in each hand. Open the book by moving the left side only, holding the right side fixed.



Figure 3: Holding and opening a book a standard way

Demonstrate this method for the class. To do so, the book will have to face them, and the side you move will be on your right instead of your left. The students will then see it as in Figure 3.

The dimensions and directions are listed in Table 1. Demonstrate these dimensions and directions with a pop-up book, and introduce the terms in Table 1.

Dimension	Directions	Description
Horizontal	back ↔ forth	Across the gutter
Vertical	up ↔ down	Along the gutter
3D	in ↔ out	Towards or away from the book

Table 1: Dimensions and directions of pop-up motion

2. **Sorting pop-ups.** One of the issues that may have come up when students first made their own pop-ups, was how to get the pop-up to move “up and down” (along the gutter) rather than “back and forth” across the gutter. Ask students to look at some pop-ups, and sketch or describe the **direction of motion of the fold line** as the book opens and closes. Figure 2 shows the directions of motion of different types of pop-ups:

- A. Pop-ups that cannot move **up and down**. (Most of the pop-ups students have made are probably in this category.)
- B. Pop-ups that can move **up-and-down** along the gutter.

Once the categories have been established, ask each group to sort all of their pop-ups according into the two types.

Science Notebook:

1. **Explain** how you decided which category each book should go in.
2. **List** the pop-up books in each category.
3. **Describe** any observations about the pop-ups in each category, which might **explain** the directions of motion

Conduct a whole-class discussion of their findings, based on what they have written in their Notebooks.

Chart their conclusions for future reference.

3. How do the hinge lines run? In Lesson 5, we looked at the four **hinges** that separate and connect the four links of a pop-up: the **gutter, fold, and two page positions**. Review these terms.
1). They should next compare the hinge lines in Type A with those in Type B:

✂ How do the four hinge lines run in each type of pop-up?

Students may notice that the hinge lines in Type A pop-ups “along run in the same direction.” In mathematics, lines that have this relationship are called **parallel**. For Type B pop-ups, they might suggest that the hinge lines “all come together” or “meet at a point.” These kinds of lines are called **intersecting**. If students make these kinds of observations about either type, ask them to look at all the pop-ups in that category, to find out whether the observations always apply.

Science Notebook

1. **Describe** what you were looking for.
2. **Discuss** what was different between the hinge lines in the two types of pop-ups
3. **Explain** why the different kinds of hinge lines lead to different kinds of motion

After they have written in their Notebooks, conduct a whole-class discussion of the results.

Outcomes

Students should find out that:

- ✂ Type A pop-ups produce horizontal but not vertical motion. In a type A pop-up all four hinge lines are parallel.
- ✂ Type B pop-ups produce both horizontal and vertical motion. In a type A pop-up all four hinge lines intersect at a point on the gutter. .

Assessment

See [Two types of Pop-up](#), next page.

Troubleshooting

Students may have difficulty seeing all three dimensions of motion. The easiest one to leave out is 3D (towards and away from the book), because all pop-ups display that kind of motion – that’s why they seem to “pop up!” Type A pop-ups have horizontal and 3D motion, while Type B pop-ups have all three: horizontal (back and forth), vertical (up and down) and 3D (in and out). In a Type B pop-up, the vertical motion is the most obvious, because most of it happens just as the book opens completely, making it the last thing you see.

If students find pop-ups that don’t fit neatly into either category, suggest they create a new one, Type C. A common type of pop-up has vertical motion, like Type B, but not along the gutter. See Figure 4. These are compound pop-ups, combining both Type A and Type B in a series connection, and will be the subject of Lessons 11 & 12.

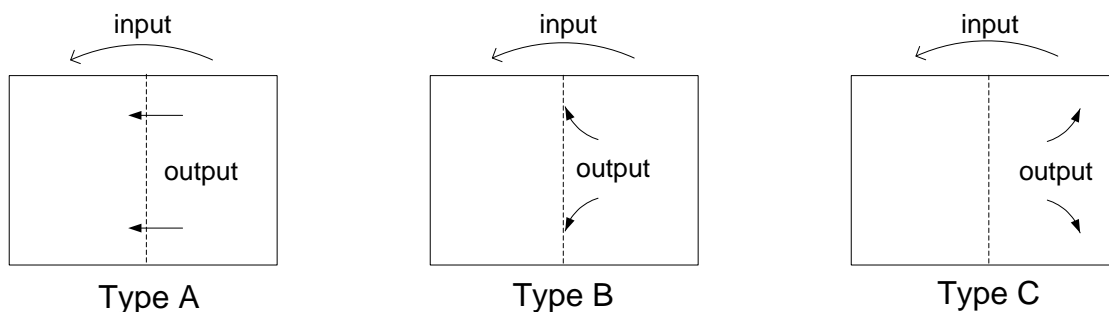

Figure 4: Three types of pop-ups, showing possible directions of motion for each type

Do not include Type C pop-ups in the search for hinge lines in Procedure Step 3. Pop-ups in Type A and Type B are simple pop-ups attached directly to the book only, and are much easier to analyze.

Name: _____ Date: _____

Two Types of Pop-up

For each type of pop-up, show how the pop-up will move and draw the four hinge lines: gutter, fold & 2 page positions.

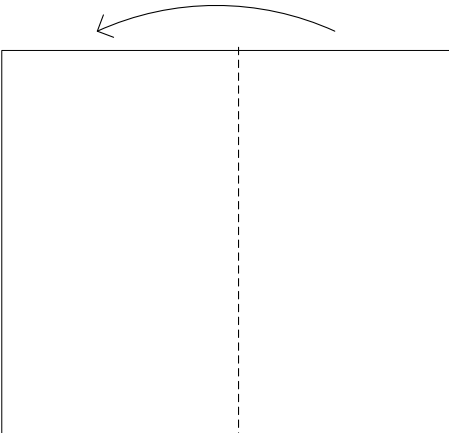
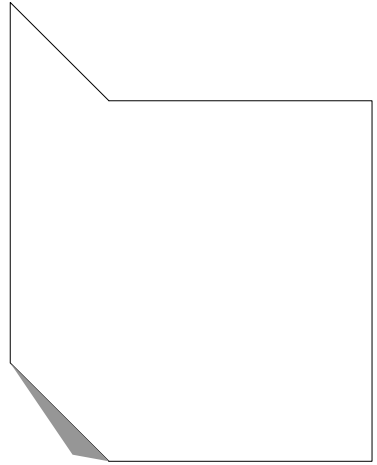
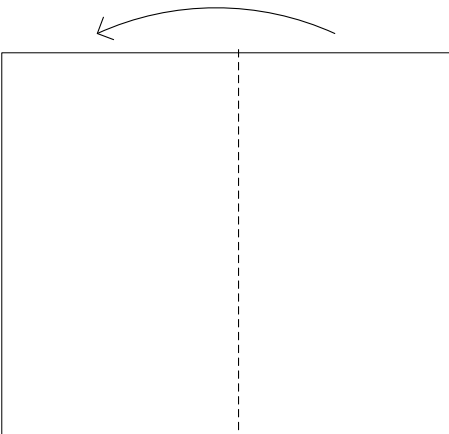
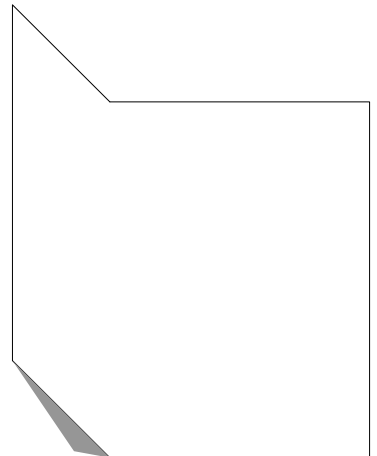
Type	Show the direction the output will move in	Draw the hinge lines
A		
B		

Type A: If you want to make a pop-up that can only move back & forth and in & out, but not up & down, how should you make your hinge lines?

Type B: If you want to make a pop-up that can move up & down as well as back & forth, how should you make your hinge lines?

Technical Background

There are two basic categories of basic pop-up mechanisms: the **parallel fold** and the **angle fold**. In the lesson, these are called Type A and Type B, respectively. See Figure 5 for diagrams of both in action. Nearly all pop-ups are built from these two basic types.

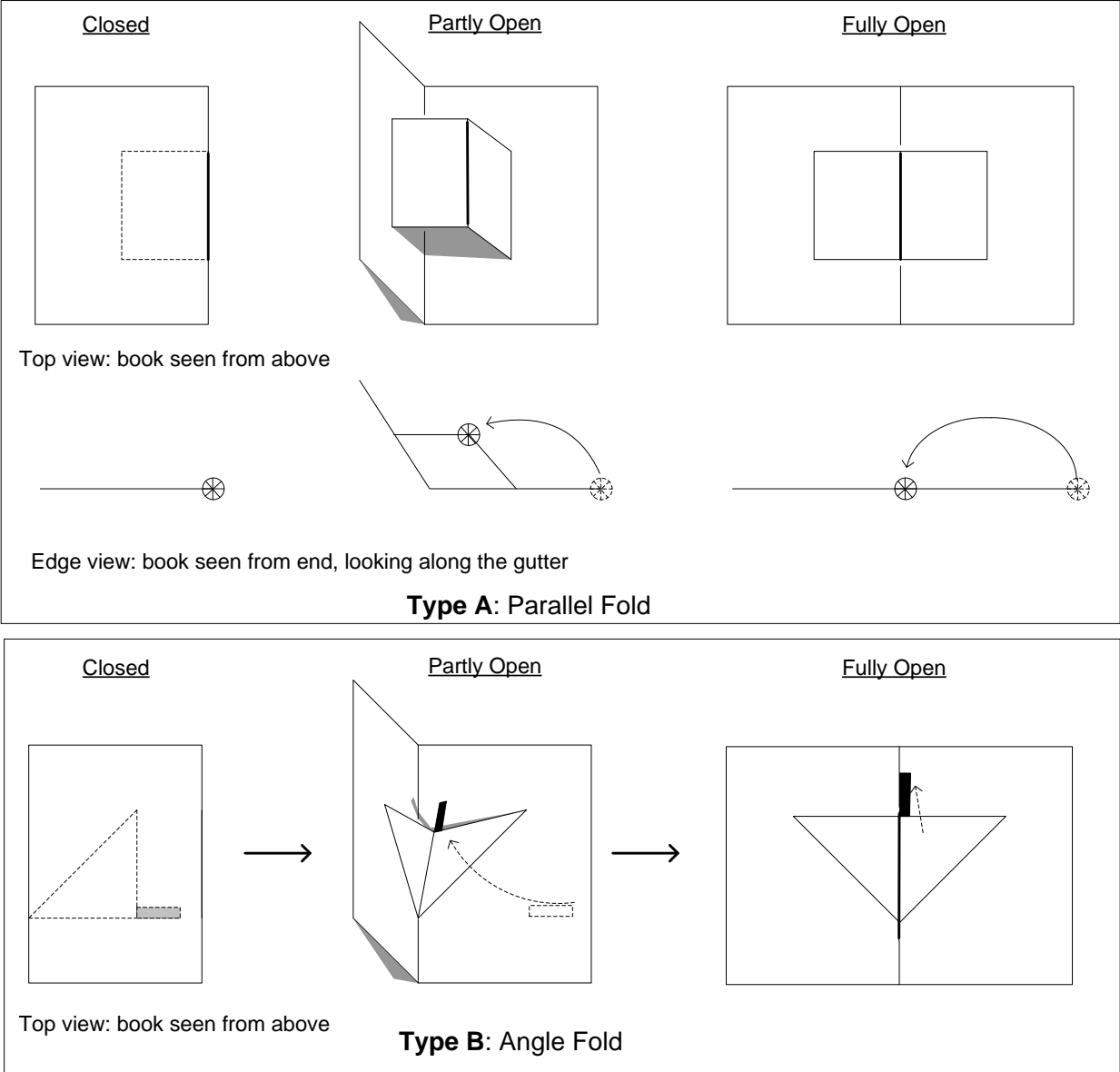

Figure 3: Two basic types of pop-up

Table 2 shows the dimensions of motion produced by the two kinds of pop-ups.

Dimension	Directions	Description	Type A: Parallel Fold	Type B: Angle fold
Horizontal	back ↔ forth	Motion across the gutter	yes	yes
Vertical	up ↔ down	Motion along the gutter	no	yes
3D	in ↔ out	Motion towards or away from the book	yes	yes

Table 2: Dimensions and directions of motion produced by each type of pop-up

Table 2 and Figures 4 & 5 show that the Parallel Fold can produce motion back-and-forth and in-and-out, but not up-and-down; while the angle fold can produce all three.

To understand the difference in operation between the two types of pop-up, let's take a brief excursion into geometry. Look at a typical, average-sized box, such as one made to hold cookies, crackers or cereal (see Figure 6). Each of its edges is a straight line. Now think about the relationships between these lines. There are only three possibilities:

- a) The top and bottom edges of the front of the box are called **parallel** because *they always remain the same distance apart*. If they are two inches apart at one place, they will be two inches apart anywhere else you measure the distance between them. (Students are sometimes told that parallel lines are lines that never meet, but skew lines also never meet. However, the distance between them changes. Compare Figures 3 b) and 3 d).)
- b) The right side and bottom edges of the front face cross at the bottom right corner. These lines are **intersecting**. (They are also **perpendicular**, which means they make a right angle when they cross. Students sometimes think that intersecting lines are always perpendicular. However, lines do not need to be perpendicular to intersect – all they need to do is cross at an angle other than zero.)
- c) The bottom front edge and the top right edge (see Figure 3 (c)) are *neither intersecting nor parallel*. These are called **skew** lines.

Now use your two index fingers to make each of these three combinations. In 3D space, this should be easy. Then put both index fingers on a flat surface, and try again: you'll be able to make them parallel or intersecting, **but not skew**. The conclusion of this experiment should be that:

In 3D space, two lines can be **parallel**, **intersecting** or **skew**.
On a 2D plane, two lines can be **parallel** or **intersecting**, but **not skew**.

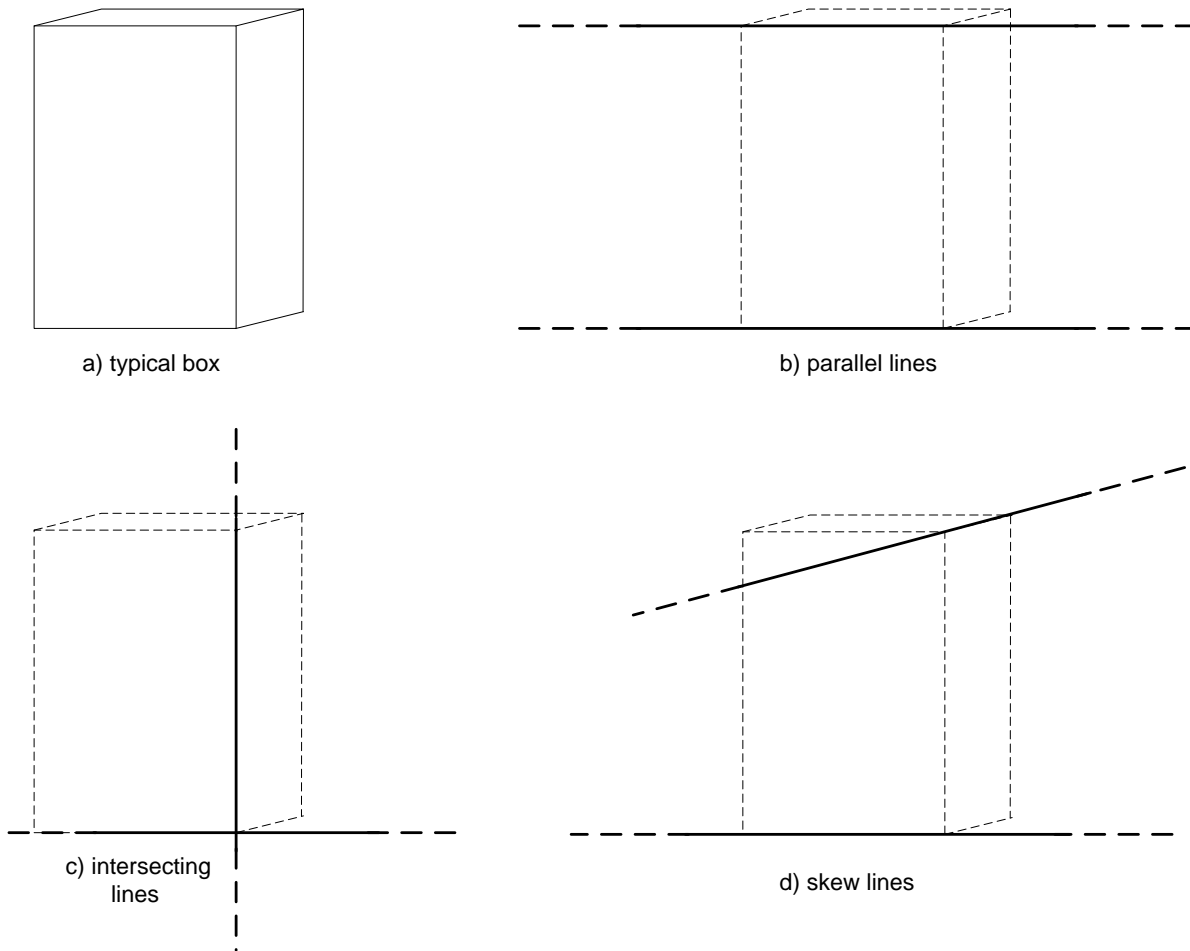

Figure 6: Lines in Space

So how does this bit of geometry apply to pop-ups? In a pop-up, there are four **hinges** that connect the four links. These hinges are called the **fold**, **gutter**, and two **page positions**. Briefly, the gutter is the spine of the book; the fold is the crease in the separate pop-up piece, and the page positions are the lines of attachments of the pop-up piece to the book. These terms are developed in detail in Lesson 1.

A hinge cannot open and close unless it is oriented along a straight line. The line that a hinge rotates around is called its **axis**. Often, we will identify the hinges just by their axes, which are always straight lines. The four hinges of a pop-up are discussed in detail in Lessons 5 & 8.

Figure 7 shows how these lines are arranged in the two types of pop-ups:

- ✂ In the **parallel fold** pop-up, all four lines are **parallel**.
- ✂ In the **angle fold** pop-up, all four lines **intersect** at the same point, which is called the **vertex**. Note, however, that the vertex might be outside the book!

Note that the term **parallel-fold** is distinct from the **parallel connection** described in Lesson 7. “Parallel-fold” refers to the orientation of the hinge lines, while “parallel connection” refers to the relationship among the subsystems. Unfortunately, these two distinct concepts use the same word.

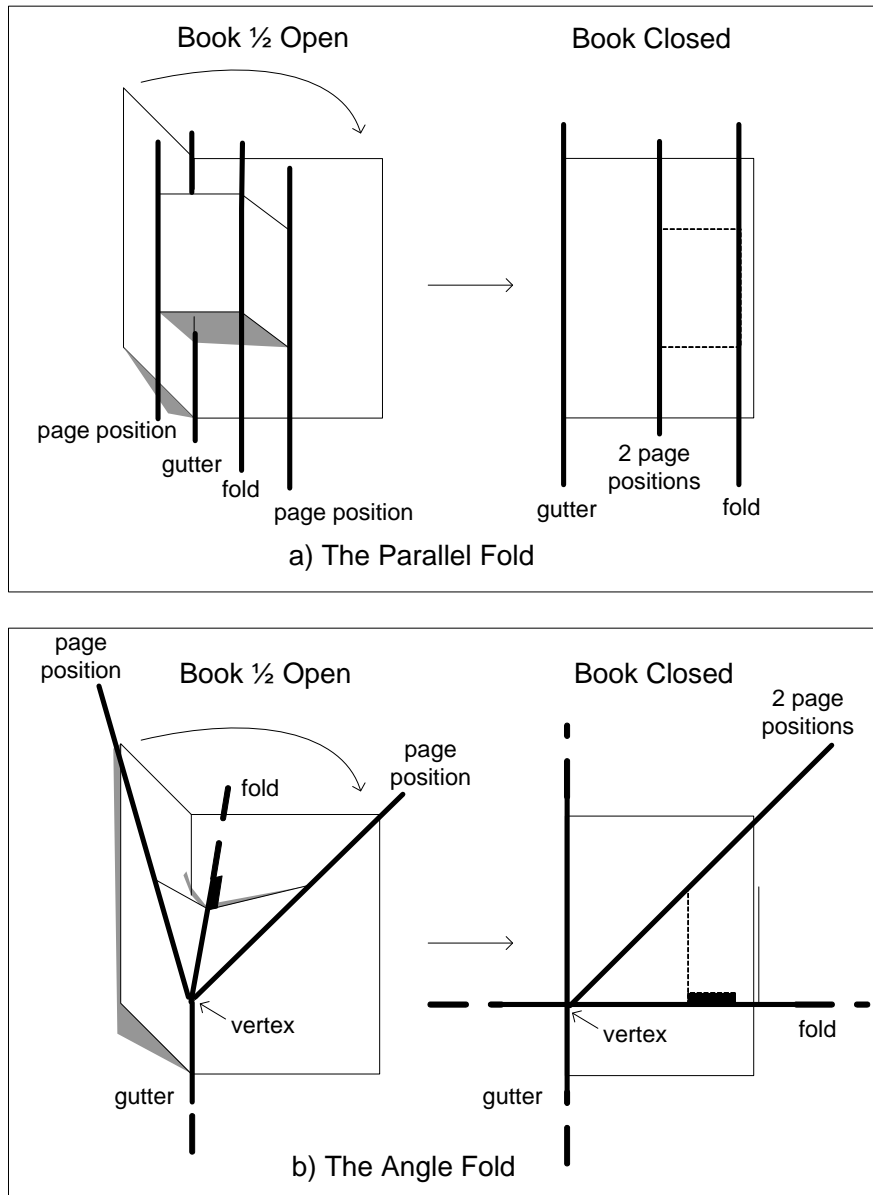

Figure 7: Hinge lines in both types of pop-ups

Now we can answer the basic question:

✂ Why can't a parallel-fold pop-up move vertically, while an angle-fold can?

As we already know, the input to a pop-up is the motion of the left side of the book (assuming the right side is held stationary). This motion exerts the force that makes the pop-up move too. However, all the force on the pop-up has to be directed across and perpendicular to the left page position hinge, because that is the only place where the pop-up piece is attached to the book. Furthermore, the component of the force that operates the pop-up has to be perpendicular to the page position line, because any force along that line will not be transmitted to the pop-up. The motion of the pop-up has to be in the same direction as the force, so the motion of any pop-up is always perpendicular to the page position.

When the page position is vertical, as in a parallel-fold pop-up, the only force that can cross at a right angle must be horizontal, so the motion is all horizontal too. The force in a particular direction is called a **force component**. In an angle-fold pop-up, the page position is at an angle to the gutter, so the force on the pop-up piece can have a vertical component as well as a horizontal component, and therefore can produce vertical motion. However, the force on a parallel-fold pop-up has no vertical component, so it can only move horizontally.

Why can't the hinge lines in a pop-up be skew to one another? You *can* make a pop-up in which the hinges are skew. In 3D, there's no problem. But when you close the book, there's one dimension less. A closed book is 2D, like a flat surface, and there are no skew lines in 2D. So, if you make a pop-up that has gutter, page position and fold lines that are skew, *you won't be able to close it, unless either:*

- ✂ New folds are forced to form when you close the book; or
- ✂ There are twists in the pop-up piece when the book is open.

In most pop-ups, the paper is not twisted, and the pop-up pieces are flat planes between folds. That's why there are only two basic kinds of pop-up: the gutter, two page positions and the fold line have to either run parallel or intersect.

Glossary

Angle: Amount of spread between two intersecting lines.

Angle-fold pop-up: A pop-up construction that produces up-and-down motion, referred to in the Lesson as Type B.

Axis: Line around which something rotates.

Force: The push or pull needed to start something moving.

Force component: The amount of force in a particular direction.

Intersecting lines: Two or more lines that meet at a common point, called the **vertex**. Intersecting lines may intersect at any nonzero angle; if they intersect at right angles they are called **perpendicular**.

Parallel lines: Two or more lines that run in the same direction without meeting, and are always the same distance apart.

Parallel-fold pop-up: A pop-up construction that cannot produce up-and-down motion, referred to in the lesson as Type A.

Perpendicular: At right angles to each other. Perpendicular lines are a special case of intersecting lines

Skew lines: Lines that come towards each other, then "miss" and separate again; they are neither intersecting nor parallel, but cannot exist in two dimensions.

Vertex: The point where intersecting lines meet.

Lesson 9: Make an Angle-fold Pop-up

Overview

Students learn to make their own angle-fold pop-ups, and explore how they work.

Materials

- ✂ **Angle-fold Template**, one per student
- ✂ **Scissors, tape, rulers, ball-point pens and Post-Its™**
- ✂ **Science notebooks**
- ✂ **Folders** or other containers for saving pop-ups, at least one per group
- ✂ **Angle-Fold Computer Template**, two per student (for Extension only)

Procedure

1. **The Basic Angle Fold:** Introduce the Angle-fold Template. They will use only one of the four triangles in this lesson – save the rest for later. Remind students to follow the directions, especially the key at the bottom left. Once they are finished, they should open & close the book a few times to see the action!

Next they should experiment with flag. Move it around to different places on the angle fold to see where they can get the most movement. Then find a way to make the movement even greater.

Science Notebook:

1. **Describe** what you did to make an angle-fold pop-up. Use a picture.
2. **Explain** how it moves when you open and close the book
3. **Discuss:** Which part of an angle fold moves the most? Which part moves the least?

2. **Assemble it unfolded:** The angle-fold made previously will lie flat when the book is open. To make it work differently, take a triangle that has not been folded. Push it in on both sides so it makes a little arch, and then tape it on both sides so the vertex touches the gutter. See Figure 1. Predict what will happen when you close the book.

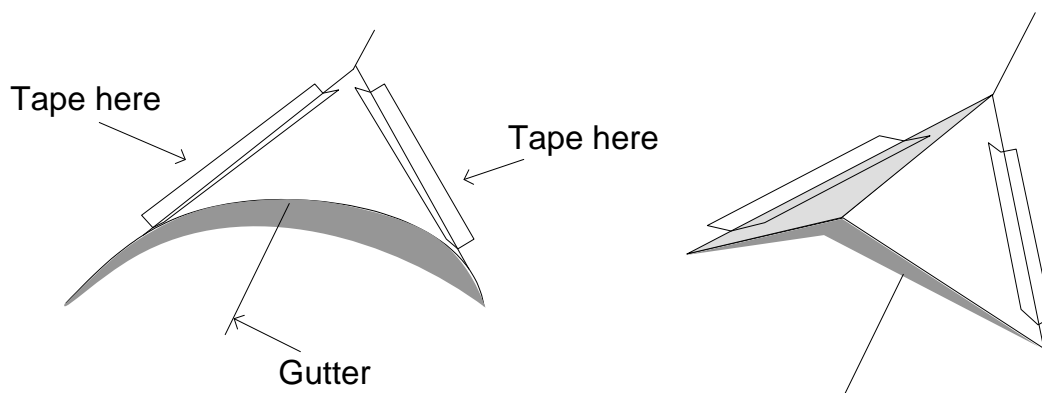

Figure 1: Angle-fold assembled unfolded (left) and after folding (right)

Science Notebook:

1. **Describe** how you made your second angle-fold pop-up. Use a picture.
2. **Predict** what you think will happen to it when you close the book.

Now allow students to close their books, pressing hard along the gutter to get a good fold. When they open their books, they should look inside to see what happened.

Science Notebook:

1. **Describe** what the pop-up looks like. Was your prediction correct?
2. **Explain** how your new pop-up is different from the first one you made.
3. **Experiment** with it to see what you can make it do.

3. Asymmetric angle folds. An angle fold that is not symmetric has different angles on the two sides of the fold. Using the same technique as in Figure 1, you can tilt the triangle to the right or left so that the angles on the two sides will be unequal, as in Figure 2. Before you close the book, predict what it will look like.

Science Notebook:

1. **Describe** how you made your pop-up. Use a picture.
2. **Predict** what you think will happen to it when you close the book.

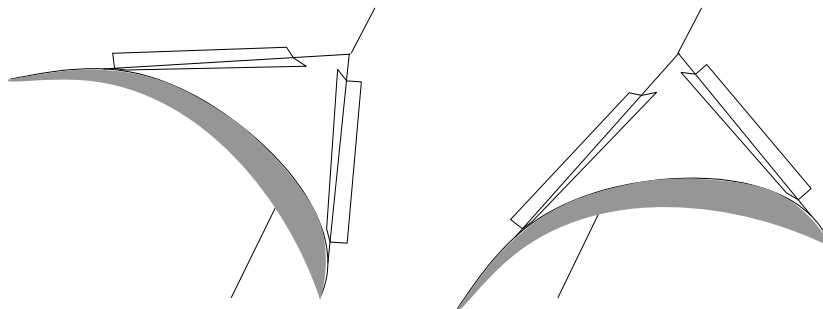

a) Triangle tilted towards the left

b) Triangle tilted towards the right

Figure 2: How to make an asymmetric angle-fold

Science Notebook:

1. **Describe** what the pop-up looks like. Was your prediction correct?
2. **Explain** how your new pop-up is different from the others you made.
3. **Experiment** with asymmetric angle-folds to see what you find out about them.

Outcomes

Students should discover that:

- ✂ The maximum amount of movement happens where the fold line ends at the flat side of the triangle, opposite the vertex. See Figure 3. To increase the amount of motion, make the flag longer, pointing away from the vertex.

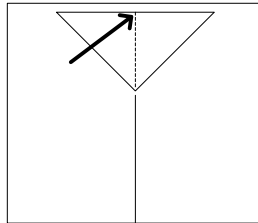

Figure 3: Showing where the motion is greatest

- ✂ An angle-fold pop-up will stand taller if it is taped in closer to the gutter – just like a parallel-fold.
- ✂ If an angle-fold is pop-up taped in asymmetrically, its fold line will lean over on the side that is farthest from the gutter. It always makes the fold on the far side, just like a parallel-fold.

Assessment

- ✂ Suppose you wanted to attach something to an angle fold to show a lot of movement. Where on the triangle should you attach it?
- ✂ How would you change an angle fold to make it stand taller when the book is open?
- ✂ If you want your angle-fold to lean over to one side, what should you do?
- ✂ How are angle-folds like parallel folds? How are they different?

Extension

This extension uses protractors to measure the angles of an angle-fold. It makes the outcomes of the experiment quantitative, and provides an angle-fold version of the Pop-up Computer.

1. The four angles of an Angle-Fold. Review the concept of an angle. To complete this activity, students should have a good intuitive sense of what a 30° , 45° , 60° , 90° , 120° , and 135° angle look like, so they will be able to check their own data. If necessary, provide practice in looking at and estimating these angles.

There are four angles that control how an angle-fold pop-up works. These are completely analogous to the link lengths A, B, C and D in a parallel-fold pop-up. The four angles are separated by the four hinge lines, just like the four links of a parallel pop-up. Figure 4 shows the hinge lines.

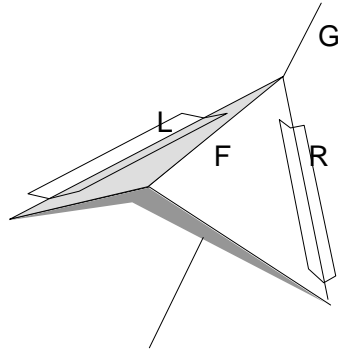

Figure 4: Angle-fold pop-up with hinges labeled

Key: Gutter (G), the Fold Line (F), the Left Page Position (L) and the Right Page Position (R)

The next step is to identify the angles between these hinge lines. There are four adjacent angles, which we'll call A, B, C and D. The definitions are exactly the same as for the parallel-fold, except that now we are looking at angles rather than distances. Table 1 shows the definitions of these angles. It is identical to Table 2 of Section 6, except that the word "Length" has been replaced by "Angle" and "Distance between" has been replaced by "Angle between":

Angle	Location	Angle Between	
A	Right side of book	gutter	right page position
B	Right side of pop-up	right page position	fold
C	Left side of pop-up	fold	left page position
D	Left side of book	left page position	gutter

Table 1: The four angles A, B, C & D of an angle-fold

These angles are illustrated in Figure 5.

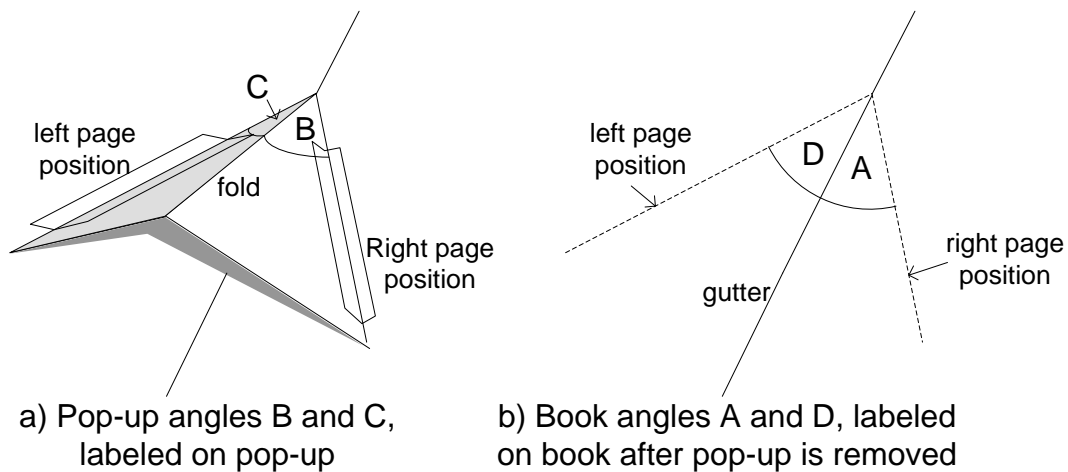

Figure 5: Angles A, B, C and D

Using this diagram as a guide, ask students to label the angles B & C directly on the pop-up, and A & D on the book.

2. The Angle-Fold Computer Template. Like the Parallel-fold, the Angle-fold Pop-up works like a computer. It solves an algebraic equation in order to figure out where to make the fold. The parallel-fold template provided rulers for measuring the lengths of the four links, A, B, C and D. In an angle-fold, A, B, C and D are angles, which are measured by protractors rather than rulers. The new template – available at the end of the [Introduction](#), provides protractors for measuring the four angles A, B, C and D.

Directions for using the Angle-fold Computer Template:

- Cut along the dashed horizontal line near the bottom of the sheet; the top portion will become the book. Cut the bottom horizontal strip along the vertical line. The two smaller rectangles will make two pop-up pieces..
- Make fold lines in both the book and the small rectangles, along the solid lines. Use standard technique: **score – fold – burnish**. Make sure the fold in the book is away from you, so the printing appears **inside** the book. Make the fold in the two rectangles point towards you, so the printing is on the **outside**.
- Cut out the semicircles in the smaller piece. Notice that a protractor has been printed onto each semicircle. The numbers represent angles in degrees, measured from the fold line. Then cut along the 60° lines on either side of the fold line. These will be the two pop-up angles B and C.
- Notice that protractors have also been printed in the book. These show you where to tape the pop-up piece into the book. These will become the book angles A and D. Place one of the pop-up pieces onto one of the protractors in the book, in between the 40° and 50° lines on either side – i.e, at about 45° . Make sure the vertex of the pop-up is at a vertex in the book, and tape the two diagonal sides along the protractor lines in the book. See Figure 6.

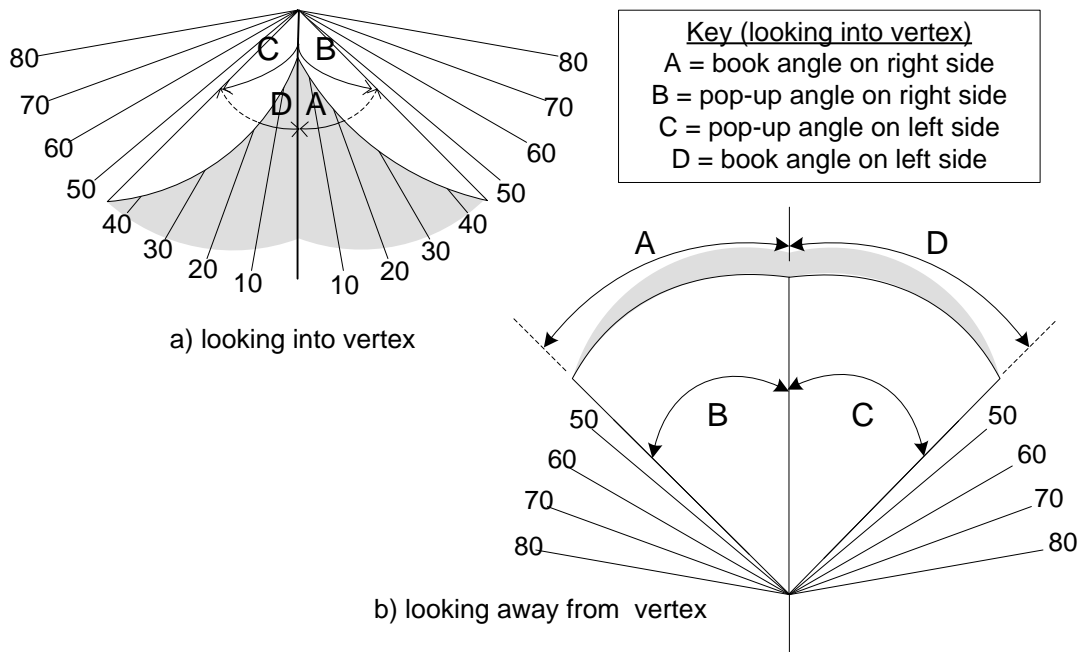

Figure 6: The Angle-Fold Computer Template using $B = C = 60^\circ$ and $A = D = 45^\circ$

3. Comparing two symmetric angle-folds. Have students tape the second pop-up piece into the book at the second protractor, but this time use $A = D = 60^\circ$. Compare how the two-ups look when the book is open:

- ✂ *What is different about the angles?*
- ✂ *How are the two pop-ups similar and how are they different?*
- ✂ *How is this experiment similar to and different from the High and Low experiment in Lesson 4?*

4. Where does it make the fold? Using another Angle-Fold Computer Template, cut out the book, the semicircles, and the 60° lines on the semicircles. Make the fold in the book, but **do not fold either of the pop-up pieces**. Tape one in unfolded at $A = D = 45^\circ$, and the other at $A = D = 60^\circ$, the same values as before. This time A and D will be known, but the book will “decide” B and C.

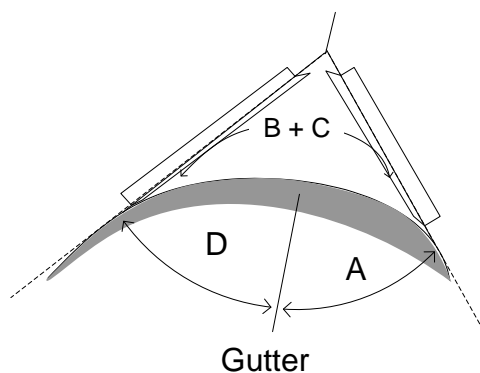

Figure 3: Pop-up piece is unfolded, so A, D, and the sum $B + C$ are set, but B and C separately are unknown

Close the book, open it again, and notice where the fold lines are. Have students record the values of A, B, C and D. Ask:

- ✂ *What pattern do you see in where it makes the fold?*
- ✂ *How is this similar to and different from the Near and Far experiment in Lesson 4?*

Ask students to use the protractor to measure B and C. Then tabulate a class chart of A, B, C and D. Ask:

- ✂ *What pattern do you notice about A, B, C and D?*
- ✂ *How is this pattern similar to and different from that of the Pop-up Computer experiment in Lesson 5?*

Troubleshooting

Table 1 shows how to diagnose and remedy common angle-fold problems.

Problem	Possible cause	Things to try
Everything comes apart	Not enough tape	Use more tape (Figure 3)
	Pop-up gets hung up	See next three rows
Book won't close easily	Book or triangle does not have a sharp fold	Score, fold and burnish along fold line
	Triangle vertex not touching gutter	Move triangle so its tip touches gutter
	Tape gets in way of triangle folding	Use less tape (Figure 3)
Inside won't pop-up	Fold points towards book	Reverse fold by lifting with finger

Table 1: What can go wrong with an angle-fold

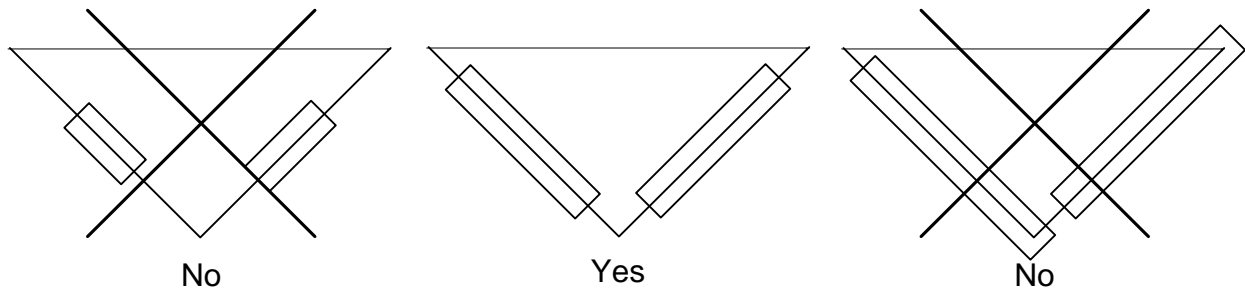

Figure 3: How to tape the angle-fold

Technical Background

1. **The Basic Angle Fold:** Maximum motion occurs at the flat edge of the triangle, furthest from the page positions and vertex (see Figure 4). The reason is that the page positions and vertex (where they meet) are taped down, and therefore can't move. The vertex acts like the axis for the rotation. Like on a merry-go round or see-saw, further you are from the axis, the further you travel.

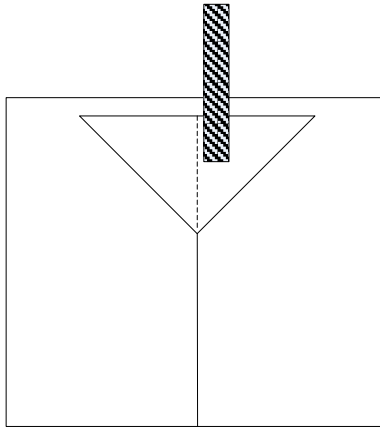

Figure 4: Where to put the flag in order to increase the amount of motion

To amplify the motion even further, attach a flag along the fold line, extending outwards away from the vertex. Why does this work? The flag is like a baseball bat and the vertex is like the shoulders of the batter. The bat and the flag both extend the swing because they are further from the place where the swing starts – the vertex. The distance from the vertex is called the **radius**, and the shape of the swing is an **arc**. The distance traveled by the swing is the **arc length**. Figure 5 shows how the arc length increases as the radius increases.

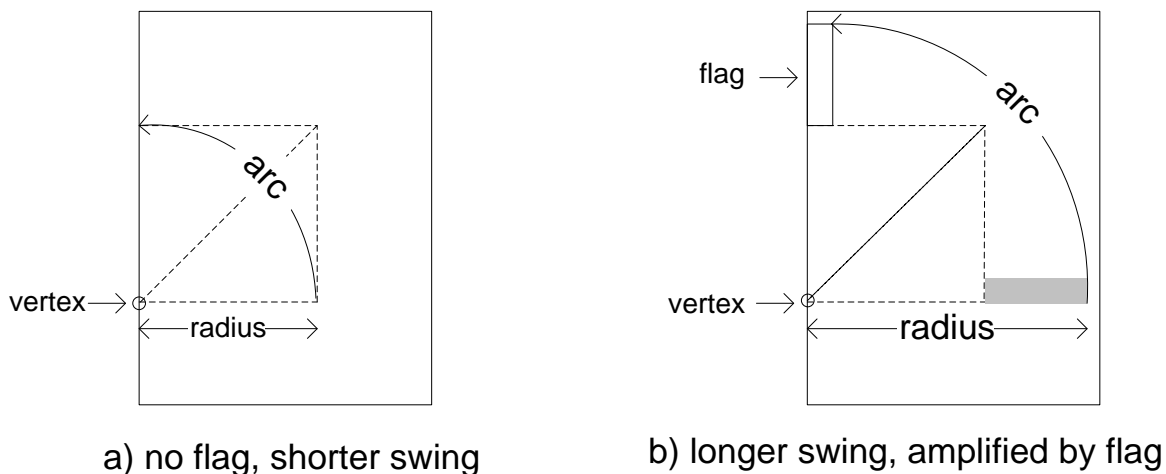

Figure 5: Adding a flag increases the radius and the arc length

2. **Assemble it unfolded:** Just like a basic parallel-fold, an angle-fold pop-up has four links, separated by the four hinges. When you assemble an angle-fold without folding the triangle first, you select the two page positions A & D by where you tape it down. However, we can no longer

measure the lengths of these two links, because they have to intersect each other and the gutter at the **vertex**, where the distance between any of these lines is zero. Then the lines extend outwards, so their distance from the each other increases. The quantity that does stay the same as two intersecting lines get further apart is the **angle** between them. The size of an angle measures how rapidly they spread apart as you move away from the vertex.

When you tape the two sides down, you are selecting the angles A and D. The unfolded triangle will become the pop-up piece. See Figure 6 a). As in a parallel-fold, it consists of two links, B and C, but these are also measured as angles, not distances. After you close the book and open it again, a fold will form between B and C, and you will be able to see each one separately, as in Figure 6 b).

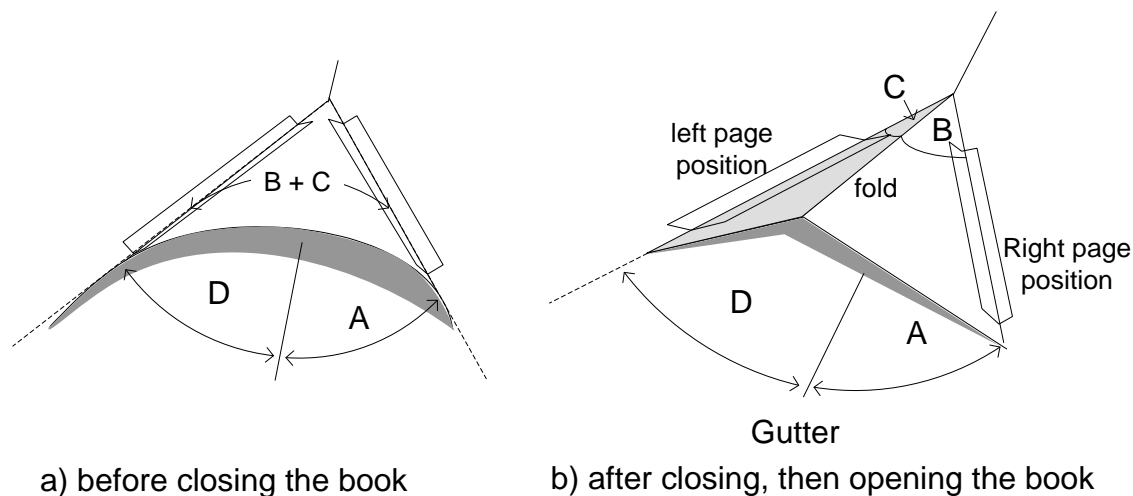

Figure 6: The four link angles in an angle-fold pop-up

On the Angle-fold Template, all four angles, A, B, C and D have already been built in: they are each 45° . Because all four angles are equal, the pop-up closes completely and opens flat.

In Procedure Step 2, students make a symmetric pop-up from an unfolded piece, as in Figure 6 b). They pinch the triangle so it does not lie flat, which forces A and D to be less than 45° each. Initially, the triangular pop-up piece is unfolded, so B and C are unknown, but their sum $B + C$ is the angle at the vertex of the triangle, which is 90° . If the pop-up is symmetric, this will divide equally, making $B = C = 45^\circ$. Making B and C larger than A and D will force the pop-up to stand up when the book is open. This is the same thing that happened with the parallel-fold in Lesson 4, except that for the angle-fold, A, B, C and D are all angles, not distances. Table 2 shows how the same observations that we made about parallel-folds are also true of angle-folds, if you just substitute the word “angle” for “distance”.

3. Asymmetric angle folds. In this part, students make angle-folds that are asymmetric. An asymmetric angle-fold has different angles A and D, which forces the other two angles B and C to be different too. Recall from Lesson 4 the observation that it always makes the fold on the far side.” The same rule applies to an asymmetric angle-fold, except that here the “far side” is the one with the greatest link angle (A or D), and the “shorter side” on the pop-up (B or C) is the one with the smaller angle. In Figure 6 b), the far side is on the left, because D is greater than A, and the book makes the fold on that side, forcing C to be less than B. See Table 2 for the correspondences between angle-folds and parallel-folds.

Observation	Parallel-Fold links	Angle-Fold links
A link is the space between hinge lines	A, B, C, and D are measured by <u>distance</u> .	A, B, C, and D are measured by <u>angle</u>
It always makes the fold on the far side	The far side is the one with the largest <u>distance</u> , between A & D	The far side is the one with the largest <u>angle</u> , between A & D
	The side with the fold has the smaller <u>distance</u> , between B & C	The side with the fold has the smaller <u>angle</u> , between B & C
A pop-up is symmetric if the page positions are equal, $A = D$	A and D are both <u>distances</u>	A and D are both <u>angles</u>
The closer a symmetric pop-up is to the gutter, the higher it will stand when the book is open	Closer means a smaller <u>distance</u> $A (= D)$	Closer means a smaller <u>angle</u> $A (= D)$
For a pop-up to close, $A + B = C + D$	A, B, C & D are all <u>distances</u>	A, B, C & D are all <u>angles</u>
For a pop-up to open flat and close $A = C$ & $B = D$		

Table 2: Comparing parallel-folds and angle-folds

Glossary

Angle: Measure of how rapidly two intersecting lines spread apart as you move away from the vertex.

Arc: Part of a circle

Arc length: distance traveled when something moves in an arc

Asymmetric angle-fold: Angle-fold with different page positions, and therefore different link angles A and D. This will force the other two link angles B and C to be different too.

Far side: Side with the larger link angle

Link angle: Angle between hinge lines in an angle-fold pop-up: A, B, C and D. These play the same role for angle-folds as the link lengths do for parallel-folds.

Radius: distance of an arc or circle from the axis

Symmetric angle-fold: Angle-fold with the same two page positions, and therefore the same link angles A and D. This will force the other two link angles B and C to be the same too.

Vertex: Point where lines intersect;

Lesson 10: The Monster and the Inside-out Monster

Overview

This lesson develops the angle-fold pop-up further. Students predict what will happen when they add a second triangle to the Angle-fold Template. They predict and explore the directions of motion of both angle-folds, and then reverse their orientation of the triangles from Lesson 9, and again predict what they will do.

Materials

- ✂ **Angle-fold Template**
- ✂ **Scissors, tape, rulers, ball-point pens and Post-Its™**
- ✂ **Science notebooks**
- ✂ **Folders or other containers for saving pop-ups**

Procedure

1. **Direction of motion of the Monster.** Show students how to tape both triangles in the positions indicated on the Angle-Fold template.

Science Notebook:

1. **Describe** how you made your pop-up. Use a picture.
2. **Predict** what you think the pop-up will do as you close and open the book.

With flags attached, it will look like in Figure 1. After making the prediction, they should try it to see what happens.

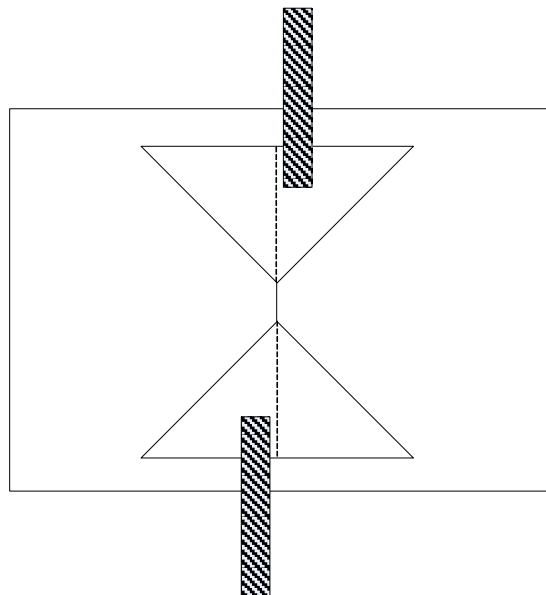

Figure 1: The monster

Science Notebook:

1. **Describe** what the pop-up looks like. Was your prediction correct?
2. **Explain** how you could use this mechanism in making your own card.

Provide time for students to experiment with this construction. It can produce very dramatic motion, as the two flags are flung in opposite directions. We call it the **Monster**, because one student attached the monster's head to the angle-fold on top, the tail to the one on the bottom, and drew the middle of the monster directly on the book. See Figure 2.



Figure 2: Miles Figaro's monster

Encourage students to experiment with this construction, to learn what they can about it.

2. **Direction of motion of the Monster.** Ask students to observe the motion of the Monster pop-up. Lead a discussion about these issues:

- ✂ Which part of the triangle is moving when the book opens or closes?
- ✂ Which part is not moving?
- ✂ What would change if the angle-fold on the top were moved to the bottom, and vice versa?

3. **Turn the triangles inside-out.** Ask students to predict what will happen if they turn each triangle around, so the vertices are pointing outward instead of inward, as in Figure 3.

Science Notebook:

1. **Describe** how you made your pop-up. Use a picture.
2. **Predict** what how you think the flags will move as when you close and open the book.

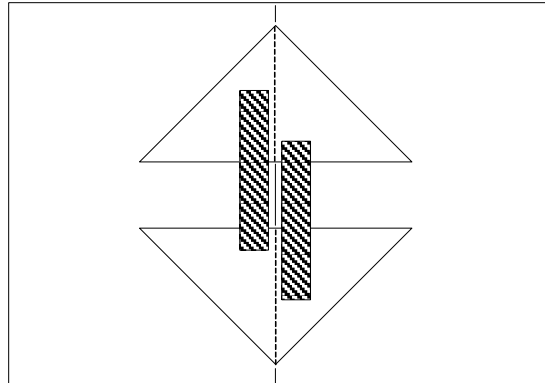

Figure 3: The Inside-out Monster

After they have made their predictions, ask students to try it and then record the results.

Science Notebook:

1. **Describe** what the pop-up looks like. Was your prediction correct?
2. **How** is it different from the Monster? How is it similar?
3. **What** should we call this construction?
4. **Explain** how you could use this mechanism in making your own card.

When you reverse the two angle-folds, the two horizontal edges will still produce the motion. As the book opens, the bottom one will go up and the top one will go down, so they will come together, like upper and lower jaws. You have probably already seen this construction used in commercial pop-up books to make a **mouth**!

Students will likely want to make more of these constructions, to see what they can make them do. After they have had some experience with this construction revisit the issues of where each pop-up produces the maximum motion, and in what direction it moves.

Outcomes

Students should become aware that:

- ✂ The maximum motion is produced where the fold crosses the horizontal side of the triangle, opposite the vertex. The direction of motion is away from the vertex, as the book opens.
- ✂ In the **Monster**, the two horizontal sides are near the top and bottom of the book. As the book opens, the flags push away from each other, above and below the edges of the book. See Figure 4 a).
- ✂ In the **Mouth**, the two horizontal sides are near the center of the book. As the book opens, the flags push towards each other. See Figure 4 b).

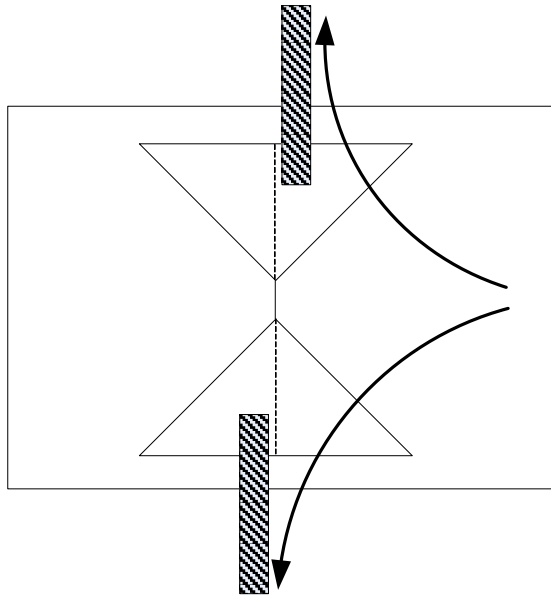

a) Monster

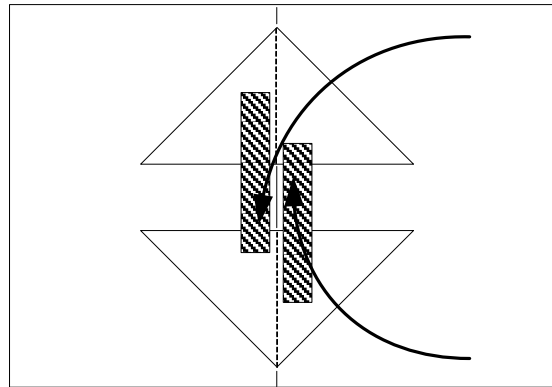

b) Mouth

Figure 4: How the Monster and Mouth move as the book is opened

Assessment

See The Monster and the Mouth, next page.

Name: _____ Date: _____

The Monster and the Mouth

1. **The Monster.** Show which way the flags move as you open the book:

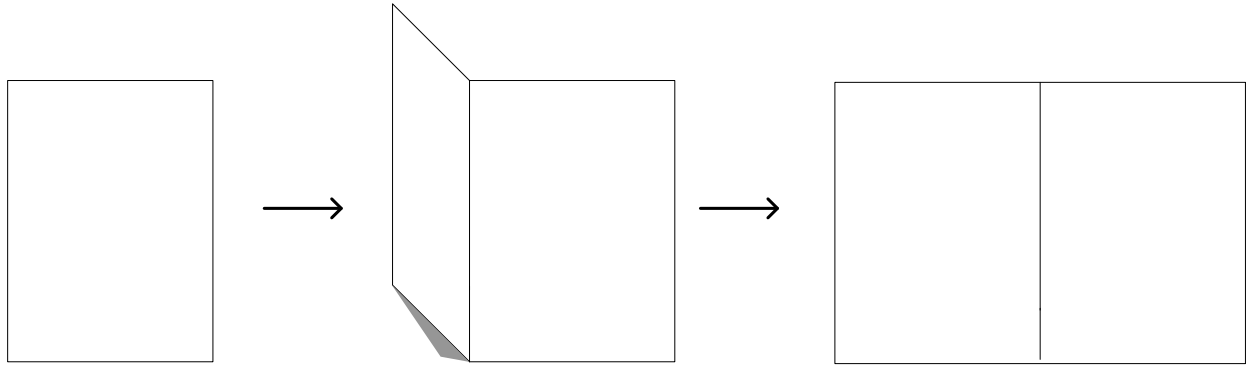

2. **The Mouth.** Show which way the flags move as you open the book:

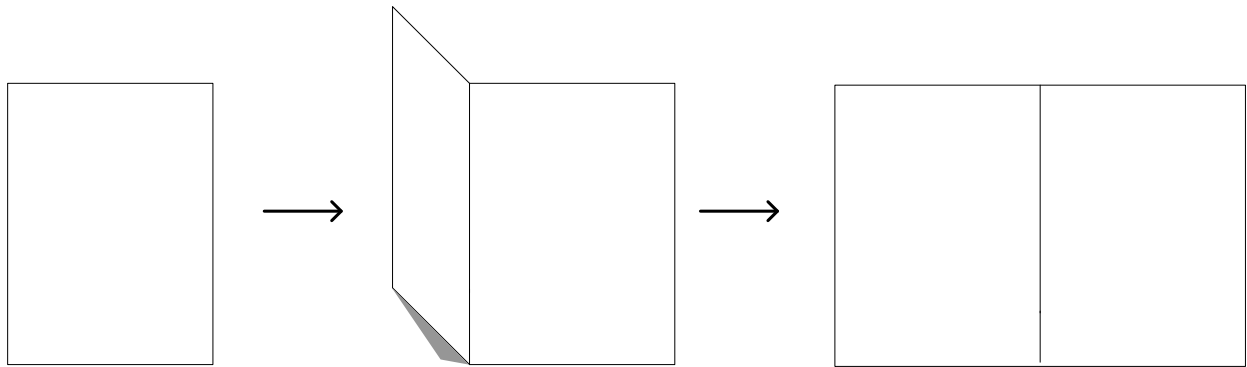

3. How is the motion similar, between the Monster and the Mouth?

4. How is the motion different, between the Monster and the Mouth?

5. Explain why they move differently.

Extensions

Experiments using the **Monster**:

- Make the flag shorter or longer, and see how this affects the amount of motion.
- Try making and attaching curved flags, as in Figure 5. Predict how they will move as the book opens and closes.
- Make the flag so long it will stick out of the book, when the book is closed. Predict where it will stick out. Find the maximum length of the flag *before* it starts to stick out.

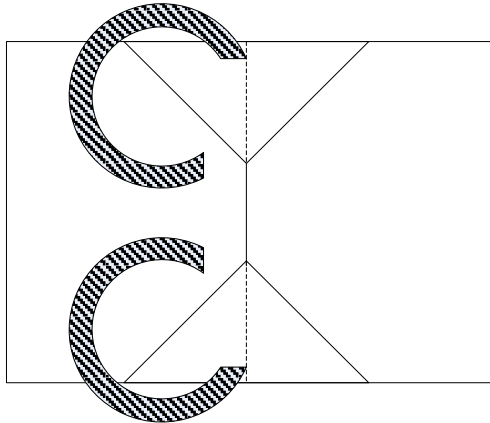

Figure 5: Monster with curved flags

Experiments and design challenges based on the **Mouth**:

- Cut teeth in each jaw. Make them so the teeth mesh when the mouth closes.
- Add a tongue. First, make a tongue that moves with one of the jaws. Then make a tongue that doesn't move, as the jaws close around it.
- Fit a small parallel fold between the two jaws. The jaws could be a dog's mouth, and the parallel fold could be the bone inside.
- Make a mouth that stands up when the book is open.
- Make a mouth whose top jaw moves less than the bottom jaw.
- See what happens when you use asymmetric angle-folds for the top and bottom jaws.
- Find examples of mouth and monster constructions in commercial pop-up books and cards.

Troubleshooting

If the angle-folds don't work properly, follow the troubleshooting hints in Lesson 9.

Technical Background

To understand the motion of an angle-fold, predict where it will hide when the book is closed. For example, look at the angle-fold in Figure 6. Where will the flag go when the book is closed?

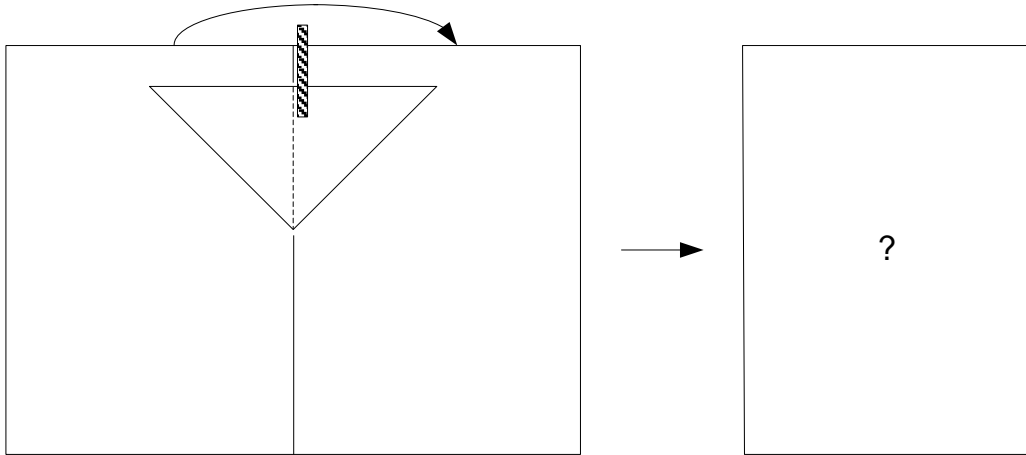

Figure 6: Where does the flag “hide” when the book is closed?

To find out the answer, you can make this construction inside the See-thru book, and try it for yourself. The results will probably surprise you. See Figure 7.

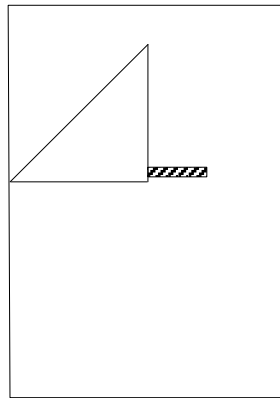

Figure 7: The answer to Figure 5

This exercise is similar to the Worksheet in Lesson 6, and the reason for the answer is similar too. Figure 8 shows how the fold line moves across the right page position, from a vertical to a horizontal position, as the book closes. To see it for yourself, construct an angle-fold inside a See-thru Book.

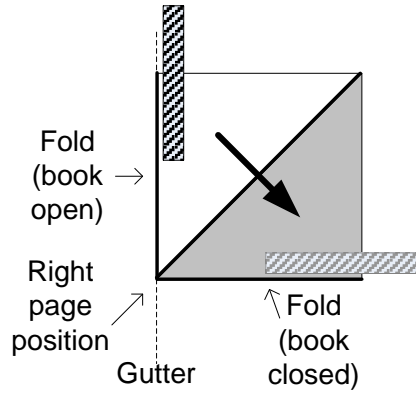

Figure 8: How the fold moves across the right page position as the book closes

The flag follows the fold line, so it too gets reflected across the right page position and winds up in a horizontal position. When the book opens, the reverse happens. The flag always travels towards the side of the triangle opposite the vertex.

Figure 9 shows the same thing happening when the triangle is turned upside down. This time, the flag moves down as the book opens, again following the side of the triangle opposite the vertex.

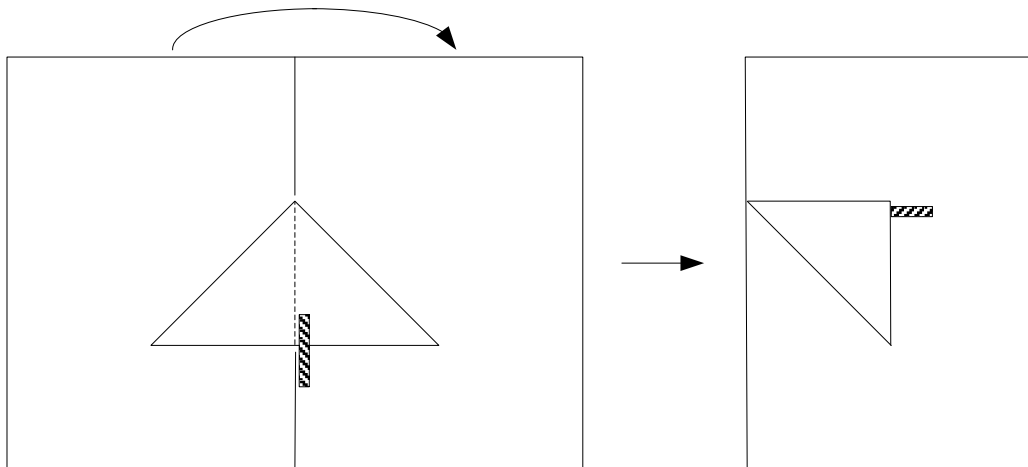

Figure 9: Motion of the flag when the triangle is turned upside down

Figure 10 shows what happens in the Monster. One triangle has its horizontal side near the top, as in Figures 5 & 6; the other has its horizontal side near the bottom, as in Figure 8.

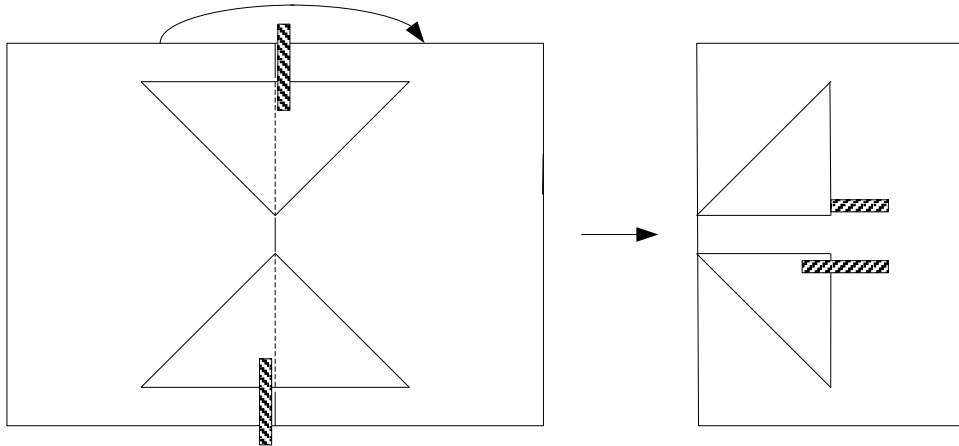

Figure 10: Where the Monster hides when the book is closed

Figure 11, finally, shows the two triangles of the Monster reversed to make the Mouth.

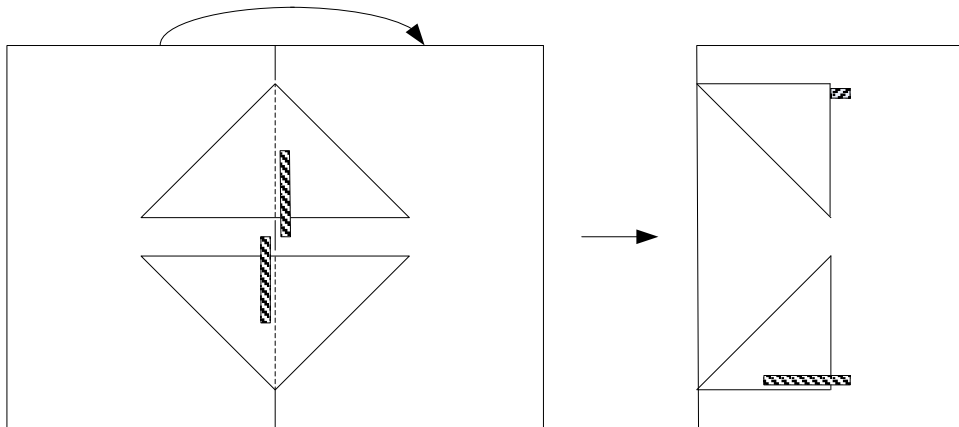

Figure 11: Where the Mouth hides when the book is closed

Extensions based on the Monster:

- a. The longer the flag, the more it will appear to move. The explanation is developed in Section 1 of Technical Background for Lesson 9.
- b. The C-shaped flags are very surprising – you have to try them to believe it! The bottom of the upper “C” travels down as the book opens, while the top of the lower “C” goes up. To see why, make the same pop-up inside the clear folder, and note carefully how the top and bottom of each “C” moves as the book opens and closes.
- c. Figure 12 shows two identical angle-folds in the same-width book, but with different-length flags. Of the two, only the flag on the right sticks out of the book when it is closed. Why? This type of angle-fold will stick out of the book or not depending on how the total radius (distance from the vertex) of the end of the flag compares with the width of the book.

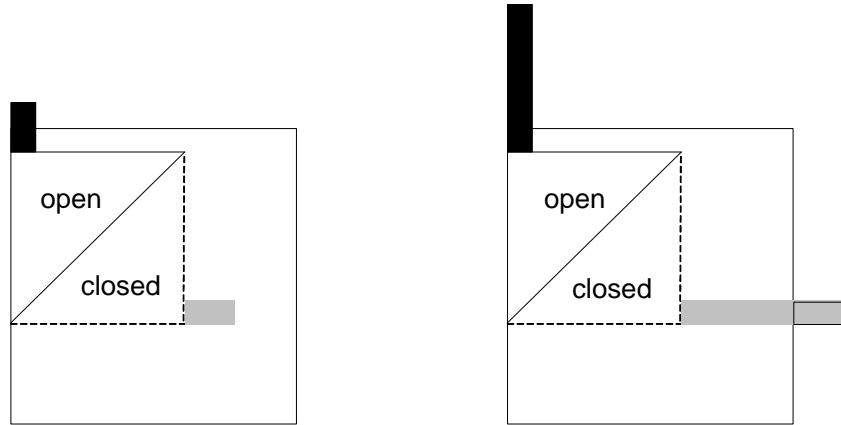

Figure 5: How the flag length affects whether or not it will stick out

Extensions based on the mouth:

- b. To make the tongue move with one of the jaws, attach it on the inside of the jaw. To make a tongue that doesn't move with a jaw, attach it to the book.
- d. To make a mouth that stands up when the book is open, use larger link angles for B & C than for A & D. Link angles A, B, C and D are discussed in Section 2 of Technical Background for Lesson 9.
- e. An angle-fold pop-up will move the most if it lies flat when the book is open. To make this happen, make angles $A = C$ and $B = D$.
- f. Using asymmetric angle-folds for the top and bottom jaws will make the mouth appear crooked when it is open.

Lesson 11: The Peek-a-Boo and the Hand-Waver

Overview

This Lesson introduces two new constructions, which each uses an angle-fold in combination with a parallel-fold. In the Peek-a-boo, the motion of the angle-fold is hidden by the parallel-fold, so it appears to “come from nowhere.” The Hand-waver uses a series connection to move the angle-fold so the action is on the side of the page, not along the gutter. These two constructions are the basis for many of the pop-ups in commercial cards and books

Materials

- ✂ Scissors, tape, rulers, ball-point pens and Post-Its™ (or paper plus glue stick)
- ✂ Pop-ups made during Lessons 8 & 9
- ✂ Assorted pop-up books and cards, from the **intermediate** category.
- ✂ Peek-a-boo Template
- ✂ Hand-Waver Template

Procedure

1. **Making a peek-a-boo.** Provide each student with the Peek-a-boo Template. Directions are printed on the template. When it is finished, it should work like in Figure 1.

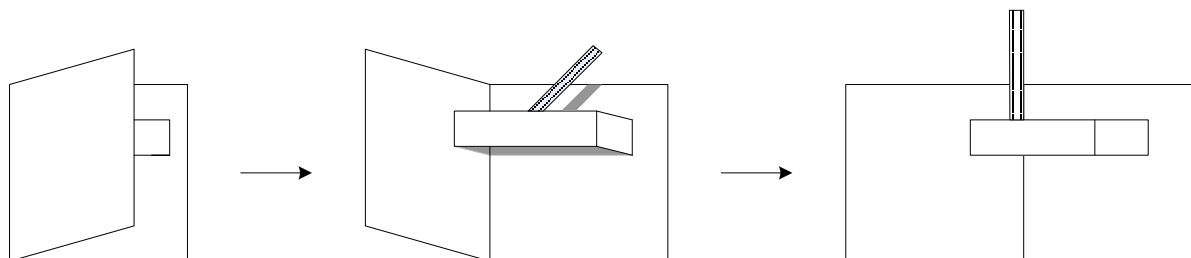

Figure 1: Peek-a-boo in action

Science Notebook:

1. **Describe** how you made your Peek-a-boo.
2. **How** is it different from the pop-ups you made before? How is it similar?
3. **Explain** how you could use this mechanism in making your own card.

Lead a discussion in which students analyze this construction to see what kinds of pop-ups it's made of, and how they are related. Some focusing questions are:

- ✂ What kinds of pop-ups can you find in the Peek-a-boo?
- ✂ In what direction does each one move?
- ✂ How are they arranged?
- ✂ Why does the flag appear to “come from nowhere” as you open the book?
- ✂ Where was the flag “hiding” when the book was closed?

Provide time for students to experiment with this construction.

2. **Make a Hand-Waver.** Provide each student with the Hand-waver Template. Directions are printed on the template. When it is finished, it should work like in Figure 2. We call it the Hand-Waver, because some students have cut the flag in the shape of a little hand, which waves “Hello” every time you open the book.

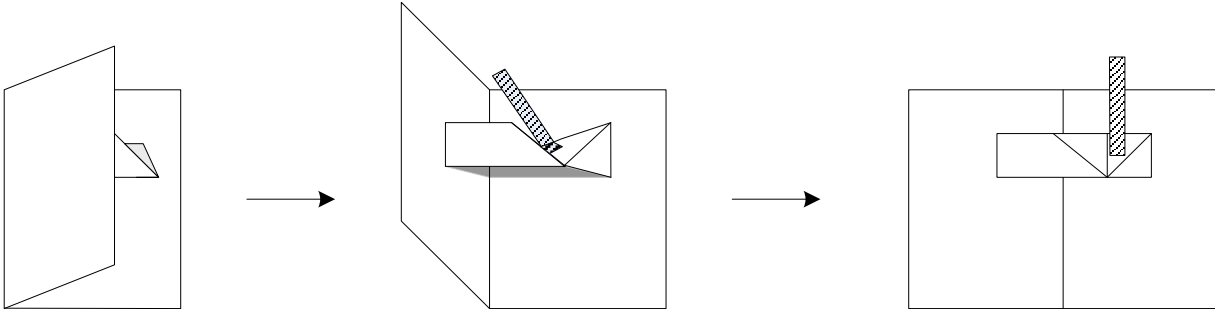

Figure 2: Hand-Waver in action

Science Notebook:

1. **Describe** how you made your Hand-waver.
2. **How** is it different from the Peek-a-boo? How is it similar?
3. **Explain** how you could use this mechanism in making your own card.

Lead a discussion about how the Hand-waver works. Help students see the Angle-fold inside the rectangle. Here are some focusing questions:

- ✂ How does the flag move?
- ✂ What is making the flag move?
- ✂ What does the triangle do?
- ✂ What is making the triangle move?
- ✂ What kinds of pop-ups does it use?
- ✂ How are they connected?
- ✂ Provide time for students to experiment with the Hand-Waver.

3. **Finding Peek-a-boos and Hand-wavers in commercial pop-up books.** Provide commercially made pop-ups that are in the intermediate category. Students should look through them to find examples that use the same constructions they have just made.

Science Notebook

1. **Describe** a pop-up you found that is like the Peek-a-boo or the Hand-Waver.
2. **How** can you tell that it uses the same construction?

Outcomes

1. Students should be able to explain that:

- ✂ The Peek-a-boo uses an angle-fold and a parallel-fold in a parallel connection (both controlled directly by the book). The upward motion of the flag is along the gutter, just like in the basic angle-fold. The flag hides inside the parallel-fold until the last moment. See Figure 3 a).
- ✂ The Hand-waver also uses a parallel-fold and an angle-fold, but only the parallel-fold is controlled directly by the book. The angle fold is controlled by the parallel-fold. The upward motion of the flag is on the right page of the book. See Figure 3 b).

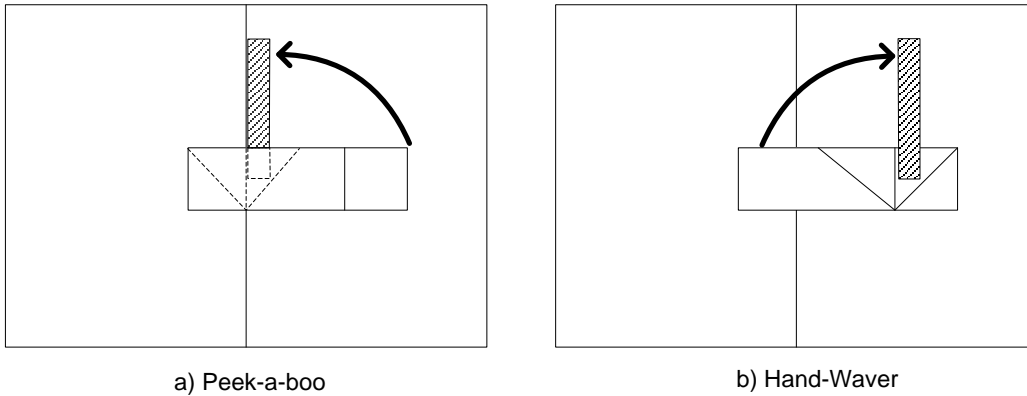

Figure 3: How the flag moves as you open the book

2. Students should be able to construct the system diagrams in Figure 4:

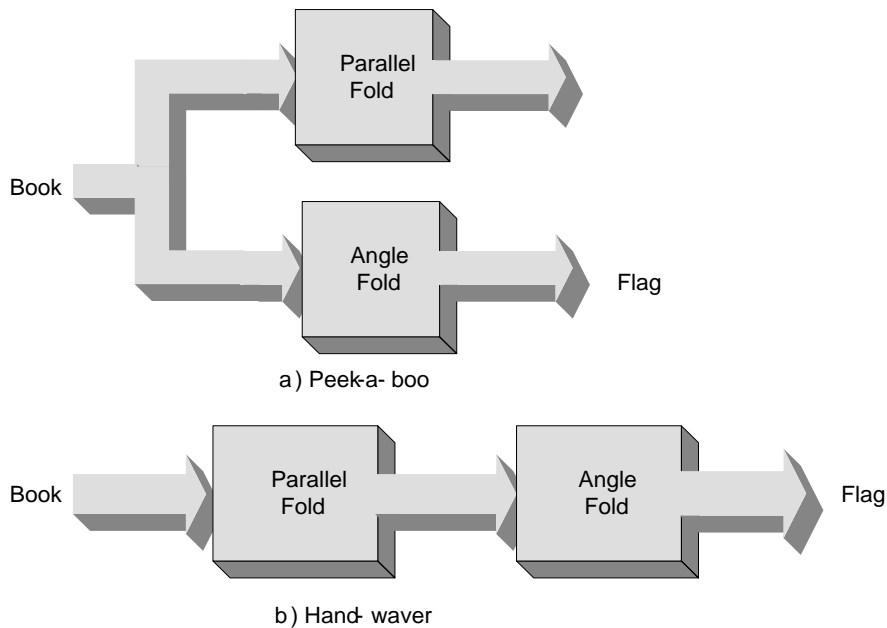

Figure 4: System diagrams

Assessment

See Peek-a-boo and Hand-waver, next page

Name: _____ Date: _____

The Peek-a-boo and the Hand-waver

1. **Direction of Motion.** Draw an arrow to show how the flag moves in each one as you open the book:

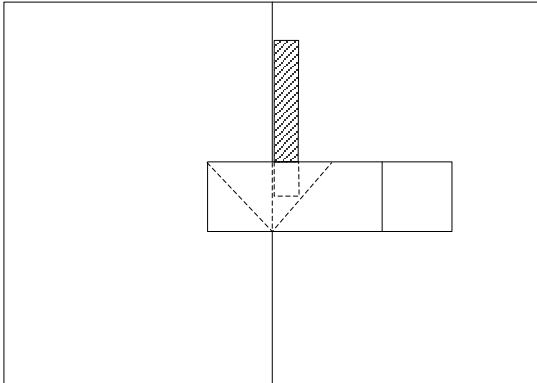

a) Peek-a-boo

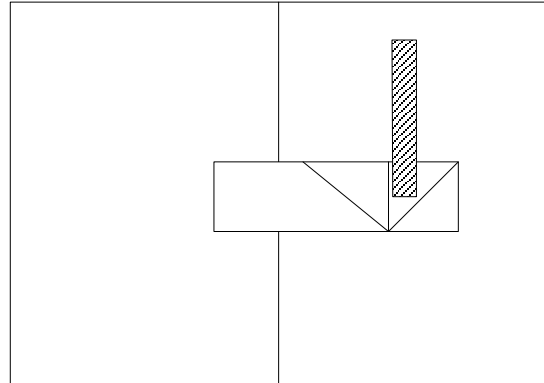

b) Hand-Waver

2. Types of pop-up

What type(s) of pop-up does the Peek-a-boo use? _____

How are they connected? _____

What type(s) of pop-up does the Handwaver use? _____

How are they connected? _____

3. **System diagrams.** Make a system diagram for each one. Label each pop-up as A (Angle-fold) or P (Parallel-fold).

Peek-a-boo

Hand-waver

Extensions

Experiments and design challenges with the Peek-a-boo:

- Predict where the fold line will occur in the parallel fold, before you close the book. Then check to location to see if you were right. HINT: Where are A, B, C and D?
- How long can you make the flag in the Peek-a-Boo? If you want to make it longer, without it bending, how can you change the design to fit a longer flag?
- The solution to a) might cause the pop-up piece to stick outside the book, when the book is closed. Look for a way to solve this problem.

Experiments and design challenges with the Hand-waver:

- Use the Peek-a-boo Template to make a Hand-Waver, with separate pieces for the angle fold and the parallel fold pieces. Tape the triangle under the rectangle, so the angle-fold is hidden, and pointing inwards towards the book (valley fold), and so the parallel-fold is pointing outwards. See Figure 5. Then attach the parallel-fold to the book to achieve the same motion as the Hand-Waver. How is this different from the original Hand-waver?

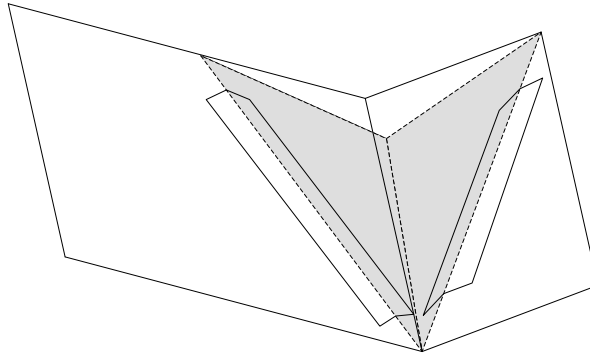

Figure 5: Angle-fold (in gray) attached under parallel fold to make two-piece Hand-waver

- Using ideas from the commercial pop-up books, find ways to hide the angle fold, so you can't see it when the book is open.
- Make a pop-up card that combines two Hand-wavers, one on top and one on the bottom. We call this construction the **Bird**, because the flags could be the wings, which come out as you open the book (see Figure 6). Make a system diagram for this pop-up and describe its symmetry.

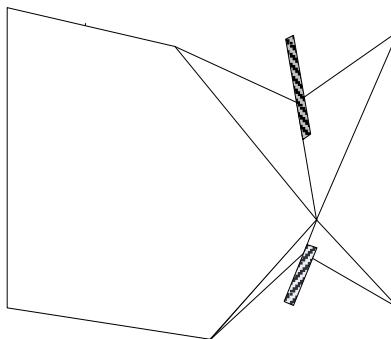

Figure 6: The Bird

- d. Make a Turtle, which produces the up-and-down motion on both sides of the page, as in Figure 7. This construction could be used to make a turtle, whose four legs all hide when the book is closed, and spread out when the book opens

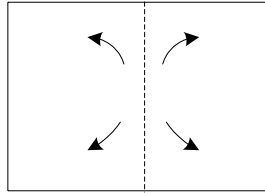

Figure 7: Arrows show motion produced by the Turtle, as book opens

Troubleshooting

Peek-a-boo

- ✂ Attach the triangle (angle-fold) first, so that it will be inside the rectangle (parallel-fold).
- ✂ If the angle-fold doesn't work properly, follow the troubleshooting hints in Lesson 9.
- ✂ Make sure the fold in the rectangle (parallel fold) is pointing outwards (mountain fold). If necessary, pull it gently as the book begins to close to make it extend towards you.
- ✂ If the flag gets crushed or bent, you can either trim it so it fits properly, or else make the parallel-fold piece larger. See Technical Background.

The Hand-waver

- ✂ Make the three folds in the proper sequence: mountain (towards you), valley (away from you), mountain (towards you).
- ✂ Burnish the three folds to make them sharp. This can be done in one step, after all three folds have been scored and made.
- ✂ If the flag gets crushed or bent, trim it so it fits properly.

Technical Background

How the Hand-waver works.

Students may have difficulty in seeing the Angle Fold inside the Hand-waver. To understand how it works, try Extension Activity a). By making a separate angle-fold, and taping it under the parallel-fold, it should be clear that the same mechanism is used in the one-piece Hand-waver. Figure 7 compares the one- and two-piece designs.

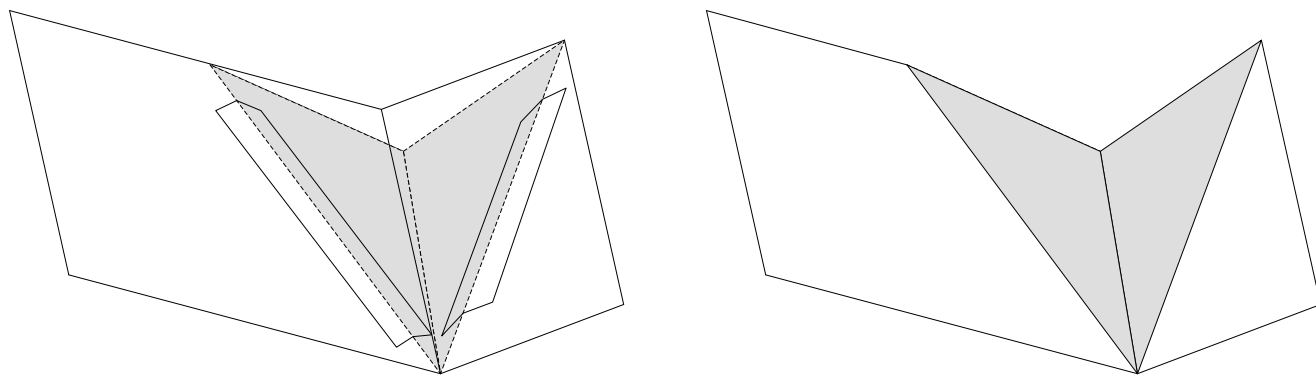

a) Two-piece design,
with separate angle- and parallel-folds

b) Original one-piece design,
with angle-fold built in to parallel-fold

Figure 7: Comparing the two Hand-waver designs

Extensions based on the Peek-a-boo

- a. The location of the parallel fold is determined by $A + B = C + D$ (see Lesson 6). The parallel fold should be made to move as far as possible, in order to be able to hide the largest possible flag. To make the parallel fold move the maximum amount, it should like flat when the book is open, which requires $A = C$ and $B = D$ (see Lesson 6 Extension). The template uses $A = C = 8$ cm. and $B = D = 5$ cm. If the parallel fold is much smaller, the flag will not fit inside. If it is bigger, the parallel fold may stick outside the book when it closes.
- b. The flag has to fit inside the parallel fold, when the book is closed. Therefore, the total length of the flag + angle fold, measured starting at the vertex, cannot be longer than link lengths $C + D (= A + B)$ of the parallel-fold. Figure 8 shows how the angle-fold and flag fit inside the parallel-fold when the book is closed. See also Technical Background for Lesson 10.

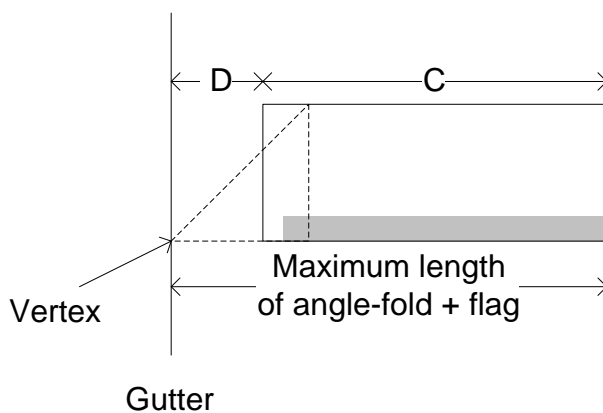

Figure 8: How the angle-fold (dashed triangle) & flag (grey rectangle) fit inside the parallel-fold when the book is closed; C and D are parallel-fold link lengths

If the flag is too long, to fit, there are two options: shorten the flag or lengthen the parallel fold. However, there are some limits on how much longer the parallel fold can be:

- ✂ If $B + C > A + D$, the parallel fold won't open flat.
- ✂ If A, B, C or D increases by more than 1 cm., the parallel fold will stick out of the book when it closed, because $A + B = C + D$ will be greater than the book width $W = 14$ cm.
- ✂ If $B + C > A + D$, the parallel fold won't open flat. See Lesson 10. Also, if B or C increases by more than 1 cm., the parallel fold will stick out of the book when it closed, because $A + B = C + D$ will be greater than the book width $W = 14$ cm.

Extensions based on the Hand-waver

- a. The two are compared in Figure 7. The advantage over the basic Hand Waver is that the angle fold is hidden, like in the Peek-a-boo. The disadvantage is that it requires another piece of paper, and more taping. The motion should be the same for both.
- b. The two-piece construction of the previous Extension offers a method of hiding the angle fold.
- c. Cut a wider piece for the parallel-fold, so it can fit angle-folds both above and below the center line. The bottom angle-fold should be a mirror image of the top one. See Figure 9 shows a System Diagram.

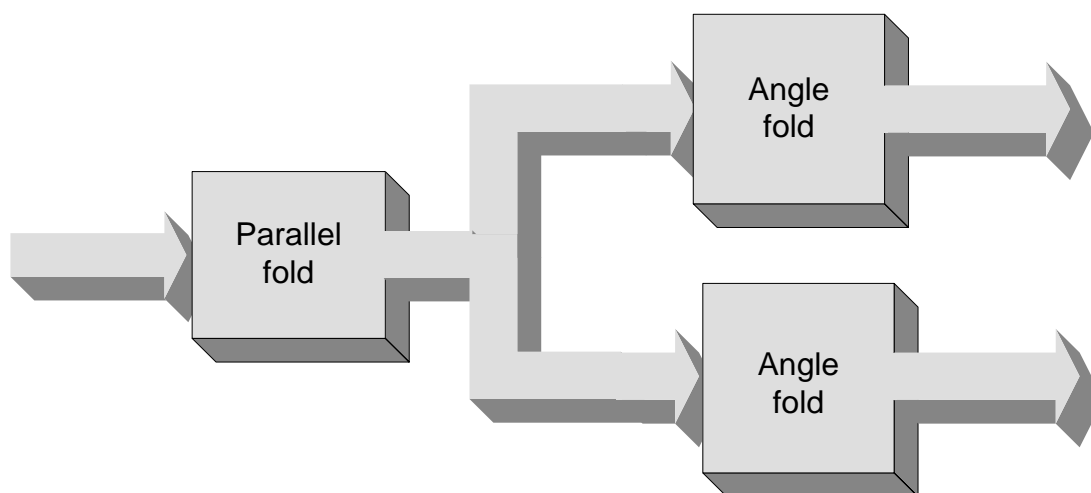

Figure 9: System diagram for the Bird

- d. The Turtle is really challenging. One method is to make a stair-step pop-up, consisting of a double hand waver attached to either side of a basic parallel fold (Figure 10 a)). The basic parallel fold should both be symmetric and also fold flat when the book is open. To do this it needs to look like a square from the edge view when the book is half open, with $A + B = C = D$. Each of the layered pieces is a Bird; see Figure 10 b). These are attached on either side of the basic parallel fold, forming layered pop-ups. The four angle folds, in turn are built into the far corners of the two layers, one on each side (Figure 10 c) through f)). In the completed construction, all four legs extend vertically up or down when the book is open, and retract inwards towards the gutter when the book closes (Figure 10 g).

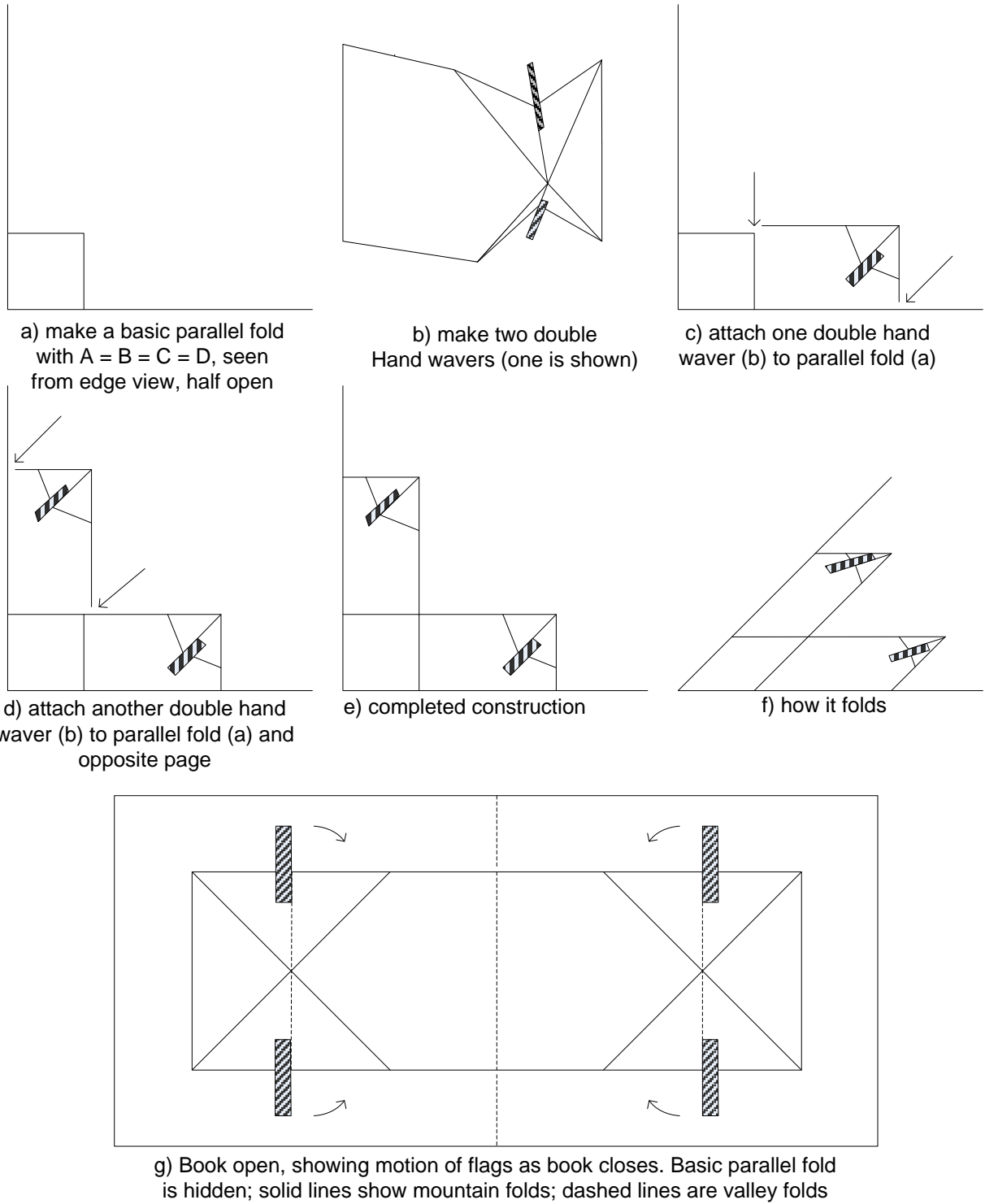

Figure 10: How to make the Turtle, incorporating two Birds, one on either side

Lesson 12: The Twister

Overview

This capstone lesson focuses on a construction that provides very interesting rotation. Like the Hand-waver, it uses a series connection between angle- and parallel-folds, but otherwise is very different.

Materials

- ✂ **Scissors, tape, rulers, ball-point pens and Post-Its™**
- ✂ **Pop-up books** that use the Twister construction (if available). These include the following pages from books by Robert Sabuda: “When snowflakes sprinkle” in Winter in White; the third and fourth days of Kwanzaa in A Kwanzaa Celebration; “Moths” in Butterflies; and “1 chocolate chip cookie” in Cookie Count.
- ✂ **Science notebooks**
- ✂ **Twister Template**

Procedure

1. **Make a Twister.** Distribute copies of Twister Template, which provides materials and directions.

Science Notebook:

1. **Describe** what the pop-up looks like. Was your prediction correct?
2. **Explain** how your new pop-up is different from the first one you made.
3. **Experiment** with it to see what you can make it do.

2. **How does it Work?** Encourage students to make as many observations as they can about the Twister. Some focusing questions are:

- ✂ How are the two triangles arranged? Have you seen this construction before? What directions do the horizontal sides move as the book opens?
- ✂ Where is the rhombus attached? What do these hinges do as the book opens? What effect do they then have on the parallelogram?
- ✂ Open the book slowly, and look under the rhombus as you do so. What shapes do you see? Do they remind you of shapes you have seen before?
- ✂ Is the rhombus part of an angle fold or a parallel fold? What is its input?
- ✂ List all the different surfaces (links) of the Twister, which move in different directions as the book opens or closes.

Science Notebook: In their Notebooks ask students to:

1. **Describe** the parts of the Twister. How does it compare with any of the pop-ups you have already made? What else does it have?
2. **Describe the motions of the parts.** How do the angle-folds move when the book opens? What does the parallelogram do? What are the different ways it rotates?
3. **Explain** how the motion occurs. Where is the parallelogram attached? How does this connection determine the motion of the parallelogram?

Provide time for students to experiment with the Twister, and to create their own pop-ups based on this construction. Figure 1 shows a Swan construction, made by a fifth grader.



Figure 1: Swans, by Miles Figaro

3. **Interdisciplinary connections.** As students work on making pop-ups, there might be opportunities to develop connections with other subject areas:

- ✂ **Art:** Decorate your pop-up, as an Art project.
- ✂ **Social Studies:** Create a pop-up that illustrates a historical event, such as the Boston Tea Party.
- ✂ **Science:** Create a pop-up that illustrates a science concept, such as lifting something against gravity.
- ✂ **Literacy:** Build a story around your pop-up.

4. Presenting Pop-ups. Here are several suggestions for culminating events, providing opportunities for students to present their designs. Obviously, more than one of these could occur:

- ✂ **Classroom presentation:** Each student shows his or her pop-up to the class. The class has to guess what it represents and how it will move when the input is operated. Students could also share the issues they encountered and what they did to solve them.
- ✂ **Bulletin board or poster display:** Pop-ups can be attached to poster boards or bulletin boards. By using push pins strategically – for example, at the corners – you can avoid interfering with the mechanism, allowing viewers to try them out to see how they work. If students have written stories or made diagrams, these can be posted too, as part of the same display.
- ✂ **Museum table:** For Parent-teacher Conferences, Open School Night, or other community events, the pop-ups can be displayed loose on tables with signs inviting viewers to guess what they will do and then test them.
- ✂ **Invention Convention:** Stage a science-fair style event, to give students an opportunity to explain their pop-ups to parents and other visitors.

Outcomes

Students should discover the following:

- ✂ The Twister is based on the Monster. It consists of a rhombus bridge, controlled by two diagonally opposite sides of a monster.
- ✂ The shape under the bridge forms a rhombus as the book opens and closes. When the book is half open, it makes a square.
- ✂ The bridge is a parallel-fold controlled by the two angle-folds of the Monster.
- ✂ There are eight different surfaces involved in the Twister: the two pages of the book, two sides on each of the two angle-folds, and the two sides of the bridge.

Assessment

- ✂ Explain how the Twister “decides” where to make the fold line in the bridge.
- ✂ Draw a system diagram for a Twister.
- ✂ Find a Twister in a commercially made pop-up book. How are they different from and how are they similar to the one you made?
- ✂ Attach a flag of a different color to each of the links of a Twister, to demonstrate all the possible directions of motion.

Troubleshooting

- ✂ If the pieces come loose, check the taping. All three pieces should be firmly attached. Each triangle should be attached to the book on both sides of the gutter, and the parallelogram should be attached to one of the triangles at either end.
- ✂ Make sure the tape extends all the way along the tape lines indicated, but not any further, because too much tape could interfere with the folding of the pieces. See Figure 2 a).
- ✂ Sometimes the tape will lift off of the parallelogram bridge, leaving a gap between it and the triangle. Reposition the bridge so the fit is as close as possible. See Figures 2 b) & c).

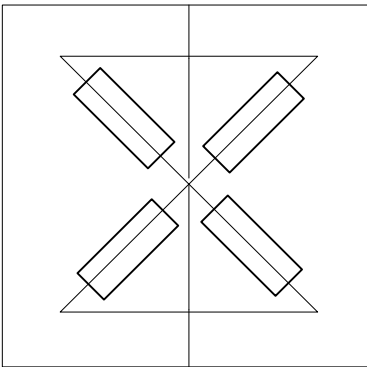

a) attach both triangles to book using Monster construction

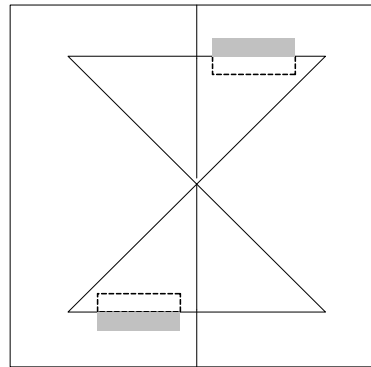

b) tape on underside of two triangles, sticky side up

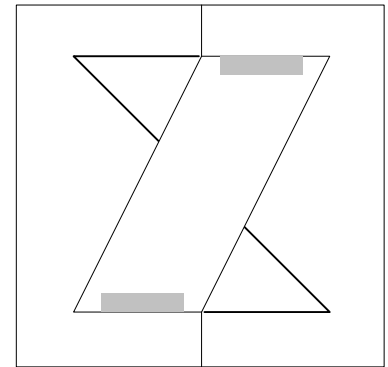

c) tape parallelogram in place, tape folded over

Figure 2: Basic steps in making a Twister

- ✂ If the parallelogram bridge doesn't fold in it, close the book again, and press hard. The fold in the bridge should be near the center.
- ✂ If the rotation isn't smooth, make sure all three folds (the two angle folds and the fold in the bridge) point outward, away from the book. Also, check the positions of the two triangles, to make sure they don't collide with each other.

Technical Background

To predict the location of the fold line in the bridge, use $A + B = C + D$, where A and D are located on the two angle folds, and B and C are on the bridge. See Figure 2. Since $A = D$, the parallel fold is symmetric, so $B = C$. Also, the bridge lies flat when the book is open, so $A = C$ and $B = D$, making all four sides equal: $A = B = C = D$. Therefore, when the book is half-pen, the shape between the bridge and the two angle-folds is a square.

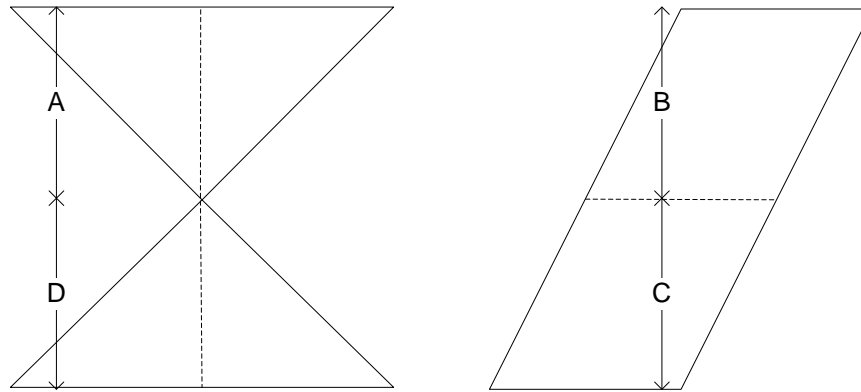

Figure 2: Showing links A, B C and D of the parallel-fold, diassembled

To make a system diagram, begin with the Monster, which consists of two angle-folds connected in parallel. These are the input to the bridge, which is a parallel-fold. See Figure 3.

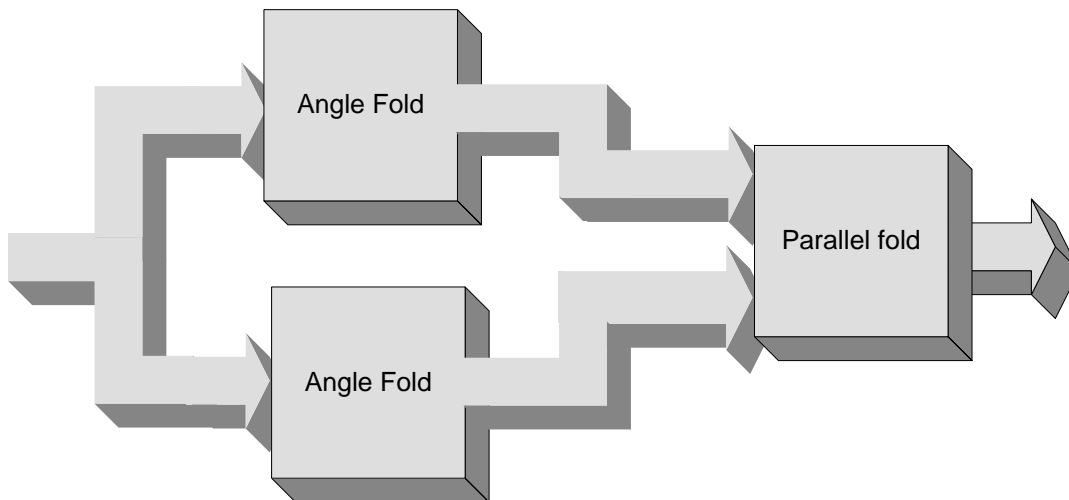

Figure 3: System diagram for the Twister

You might wonder why the parallel fold in Figure 3 has two inputs, while all the other boxes we've made have only one input each. The answer has to do with how we've been thinking about the input to a basic pop-up, whose input is the opening and closing of the book. Our assumption has been that the right side of the book is held fixed, so that the only input is the left side, which is movable. The parallel fold in the Twister has two inputs, because both angle folds that power it are moving at the same time.

The Twister has a total of eight links, each moving differently, which is why its movements seem so complex. All eight planes are shown in Figure 4.

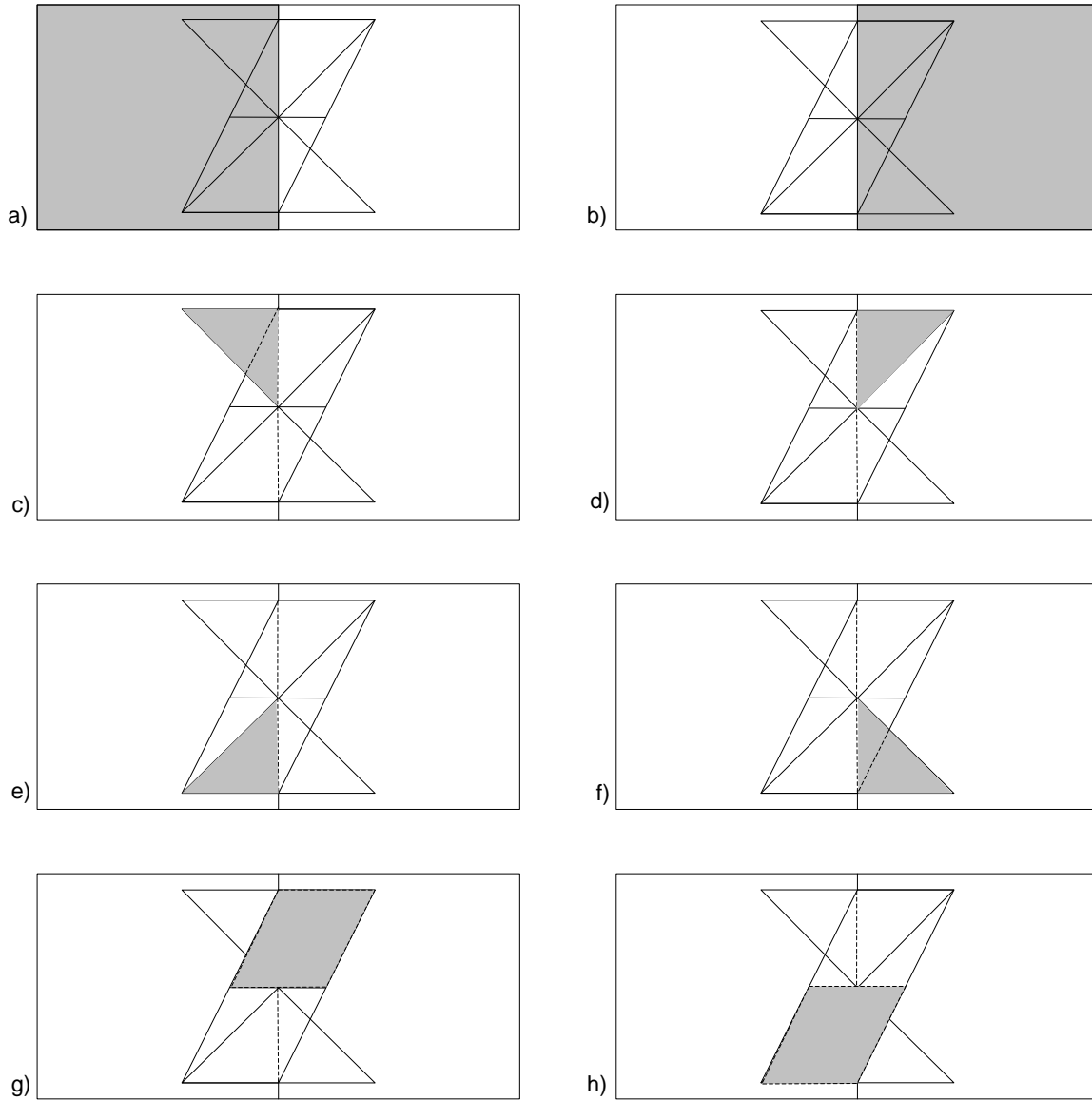

Figure 4: The eight links of the Twister:
book a) & b); two angle-folds c), d), e) & f); and parallel-fold g) & h).